

SAGITTARIUS

TAPS & SHOWERING

Finishes	Chrome
Product Type	Contemporary
Water Pressure Tested Between	Min. 0.2 bar, Max. 6.0 bar
Standards	Complies with BS6920, BS EN200
Cartridge	35mm Cartridge
Aerator	Neoperl Aerator

Guarantee 10 years against manufacturing faults (excluding serviceable parts)

Additional Information Supplied with waste (UK only)

**MONO BASIN MIXER INC
WASTE
ZE/106**



Operating Water Pressure



LOW PRESSURE
0.2-0.5 bar



COMBI BOILER



HIGH PRESSURE
1.2-1.5+ bar

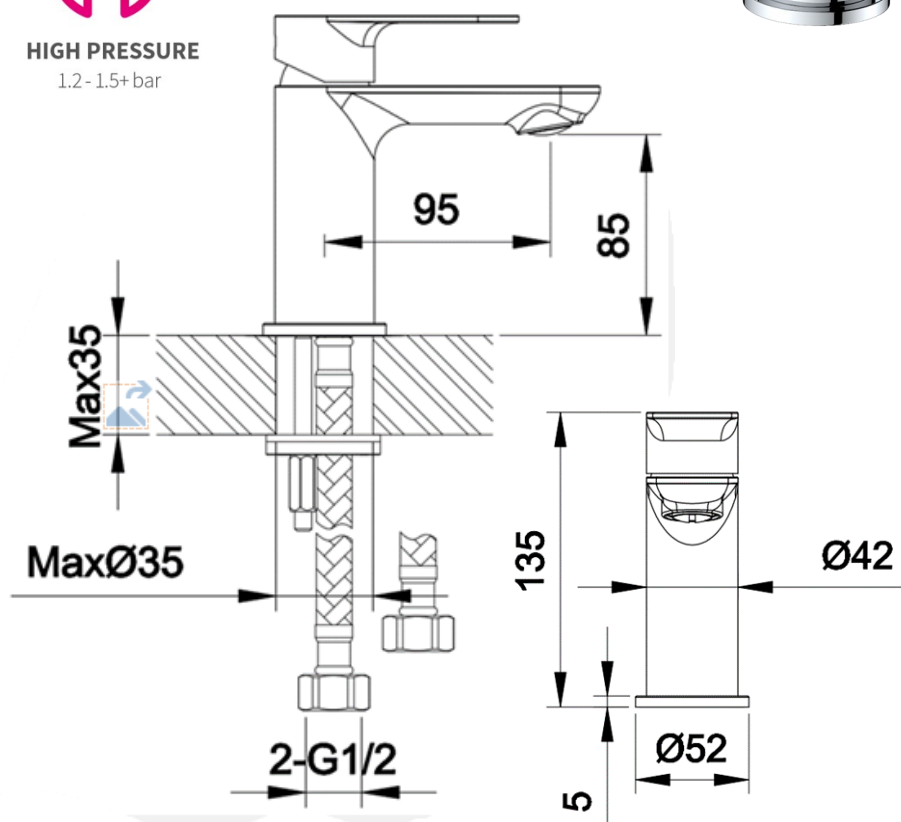

The information contained on this page was correct at the date of issue. Fitting dimensions are provided as a guide only. Some variation may occur due to manufacturing tolerances. We pursue a policy of continuing improvement in design and performance of our products and so reserve the right to change specifications without prior notice

FOR FURTHER ADVICE PLEASE CONTACT :-

SAGITTARIUS LTD UNIT 1 LOWER VICTORIA STREET—CHADDERTON—OLDHAM—OL9 9TU TEL:0616 6202029

EMAIL:TECHNICAL@SAGITTARIUSTAPS.CO.UK

Flow Rates (Litres per minute)

System Pressure	0.1 Bar	0.2 Bar	0.3 Bar	0.5 Bar	1.0 Bar	1.5 Bar	2.0 Bar	3.0 Bar	4.0 Bar	5.0 Bar
	-	-	-	9.8	11.6	-	15.2	18.5	21.0	-

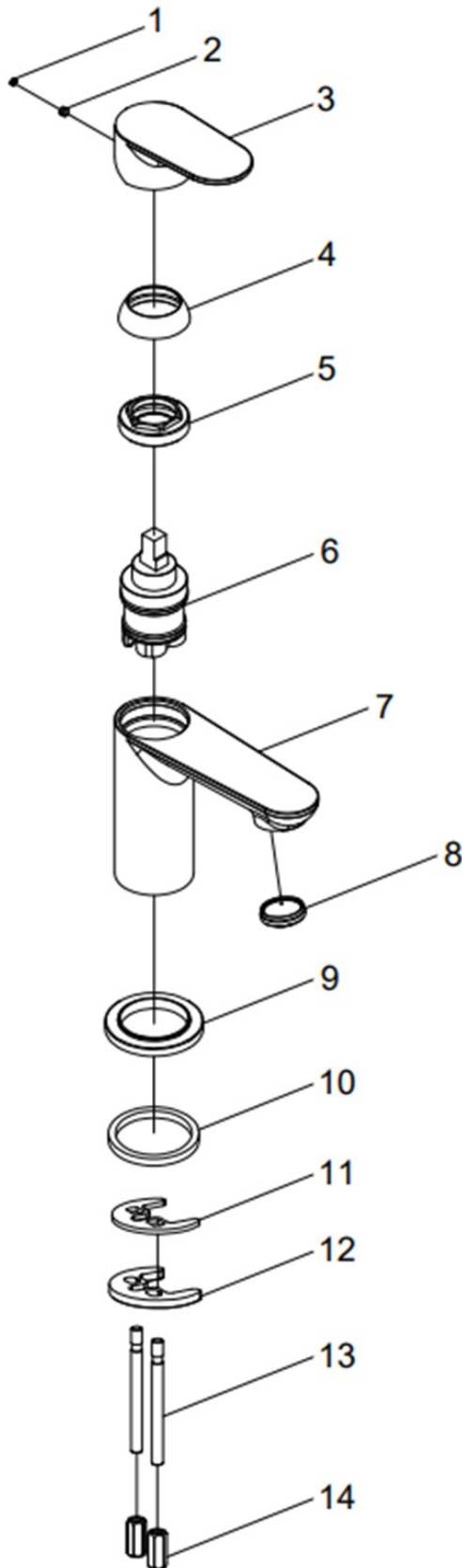

NO.	PARTS DESCRIPTION	QTY
1-2.	Cap and Grub Screw	1
3	Zinc-alloy Handle	1
4	Handle Collar	1
5	Brass Cartridge Nut	1
6	35mm Cartridge	1
7	Brass Tap Body	1
8	Aerator	1
9	Base Plate	1
10	Washer	1
11-14.	Fitting Kit	1

FOR FURTHER ADVICE PLEASE CONTACT :-

SAGITTARIUS LTD UNIT 1 LOWER VICTORIA STREET—CHADDERTON—OLDHAM—OL9 9TU TEL:0616 6202029

EMAIL:TECHNICAL@SAGITTARIUSTAPS.CO.UK