

SAGITTARIUS

TAPS & SHOWERING

Construction	Brass Body (CuZn38Pb18); Stainless steel Riser rail; ABS Handles
Finishes	Chrome plated to BS EN 248
Product Type	Contemporary
Water Pressure Tested Between	Min. 0.5 bar (Handset) 1.0 bar (Shower Head), Max. 6.0 bar
Standards	Complies with BSEN 1111
Certification	Pending WRAS approval, Manufactured to comply with WRAS
Cartridge	Thermostatic cartridge and Integrated Ceramic disc valve diverter
Check valve	0.5-10 gpm
Fitting	Metal S-Unions G3/4" Male BSP x G1/2" Male BSP offset connectors (Escutcheon); One Brass G3/4" and One G1/2" BSP Male thread outlet connection
Guarantee	10 years against manufacturing faults (excluding serviceable parts)
Additional Information	<p>Temperature: Pre-set 38°C, with push button override to 48°C</p> <p>Automatic shut off in the event of hot or cold water supply failure</p> <p>Shower head : Chrome , ABS , Ø200mm , rubber nozzles</p> <p>Shower handset : Chrome , ABS , 3 modes , G1/2" BSP</p> <p>Shower hose : Chrome , Stainless steel double interlock , 1.5m , G1/2" BSP</p> <p>Riser Rail : Chrome adjustable height rail with adjustable ABS handset holder</p>

DREAM EXPOSED VALVE AND RISER KIT CHROME

SS/609/C



Flow Rates (Litres per minute)

System Pressure	0.1 Bar	0.2 Bar	0.3 Bar	0.5 Bar	1.0 Bar	1.5 Bar	2.0 Bar	3.0 Bar	4.0 Bar	5.0 Bar
	2.0	4.4	-	7.2	11.8	-	-	18.2	-	-

The information contained on this page was correct at the date of issue. Fitting dimensions are provided as a guide only. Some variation may occur due to manufacturing tolerances. We pursue a policy of continuing improvement in design and performance of our products and so reserve the right to change specifications without prior notice

FOR FURTHER ADVICE PLEASE CONTACT :-

SAGITTARIUS LTD UNIT 1 LOWER VICTORIA STREET—CHADDERTON—OLDHAM—OL9 9TU TEL:0616 6202029

EMAIL:TECHNICAL@SAGITTARIUSTAPS.CO.UK

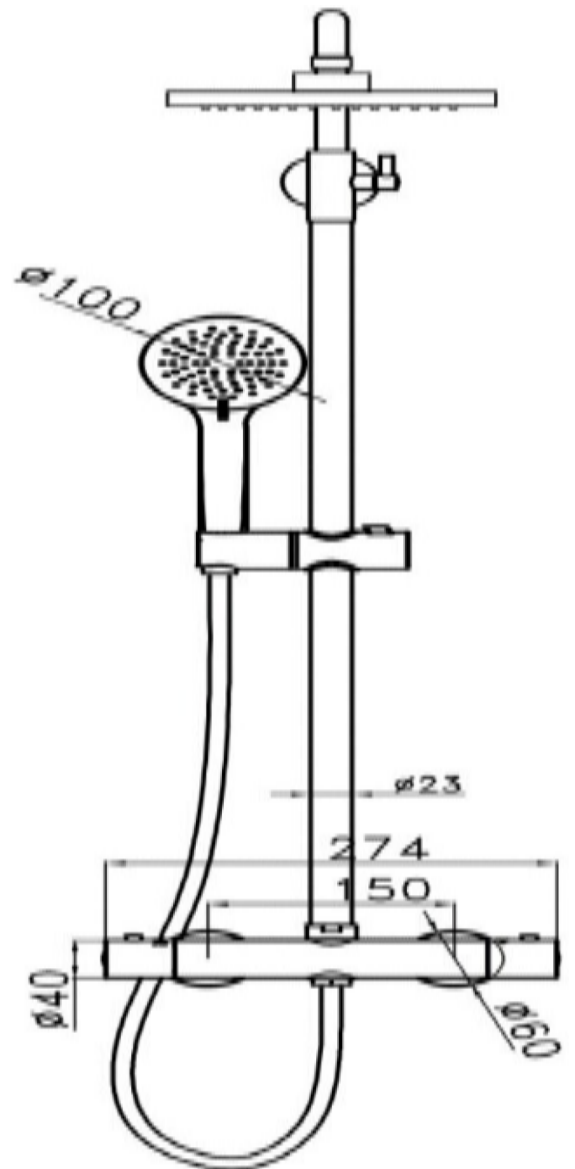
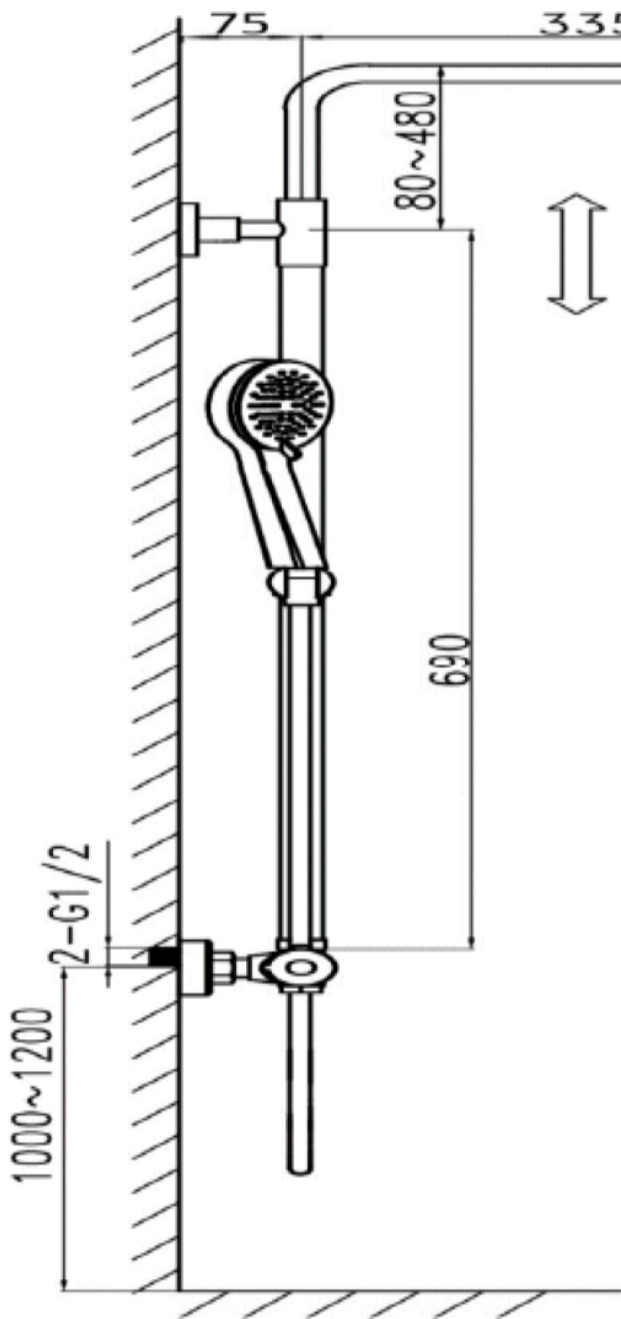

FOR FURTHER ADVICE PLEASE CONTACT :-
 SAGITTARIUS LTD UNIT 1 LOWER VICTORIA STREET—CHADDERTON—OLDHAM—OL9 9TU TEL:0616 6202029
 EMAIL:TECHNICAL@SAGITTARIUSTAPS.CO.UK

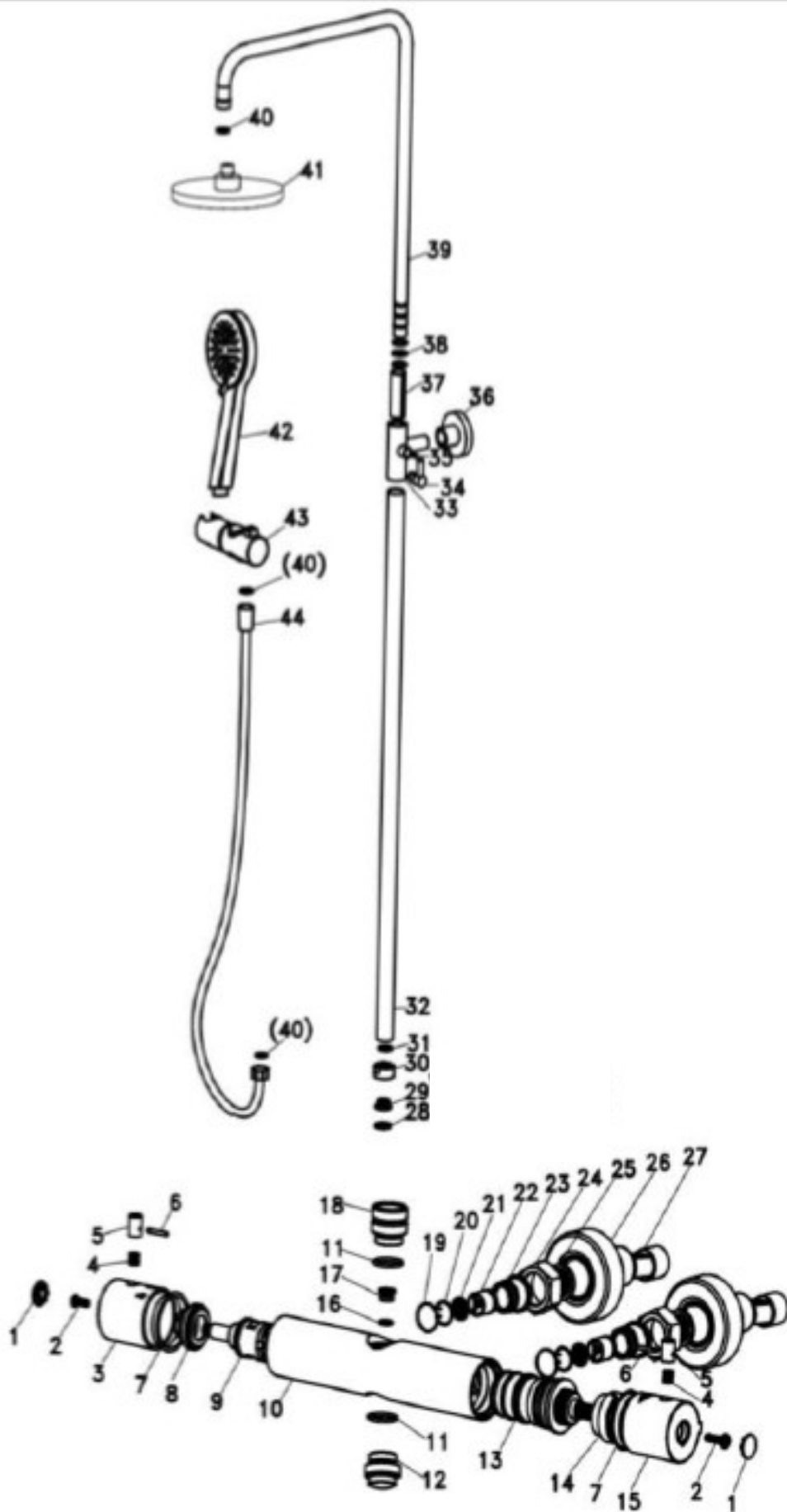

NO	NAME	QTY
1	CAP	2
2	SCREW	2
3	FLOW-BUNDLE	1
4	SPRING	2
5	BUTTON	2
6	STEM	2
7	WASHER	2
8	CARTRIDGE-NUT	1
9	FLOW-CARTRIDGE	1
10	BODY	1
11	O-RING	2
12	G1/2-OUTLET	1
13	THERMO-CARTRIDGE	1
14	POSITIONING-WASHER	1
15	THERMO-HANDLE	1
16	O-RING	1
17	CONNECTOR	1
18	G3/4-CONNECTOR	1
19	O-RING	2
20	CLAMP-RING	2
21	FILTER	2
22	CHECK-VALVE	2
23	CONNECTOR	2
24	NUT	2
25	WASHER	2
26	RAIL-COVER	2
27	OFFSET-CONNECTOR	2
28	BUBBER-SEAL	1
29	CONNECTOR	1
30	NUT	1
31	O-RING	1
32	RAIL-PIPE	1
33	PIPE-CONNECTOR	1
34	HANDLE	1
35	SCREW	2
36	RAIL-FIX-PALTE	1
37	PLASTIC	1
38	O-RING	3
39	RAIL-PIPE-UPPER	1
40	O-RING	3
41	SHOWER-HEAD	1
42	HANDSET	1
43	HANDSET-HOLDER	1
44	HOSE	1

FOR FURTHER ADVICE PLEASE CONTACT :-
 SAGITTARIUS LTD UNIT 1 LOWER VICTORIA STREET—CHADDERTON—OLDHAM—OL9 9TU TEL:0616 6202029
 EMAIL:TECHNICAL@SAGITTARIUSTAPS.CO.UK