

SAGITTARIUS

TAPS & SHOWERING

Height - 130mm
Width - 85mm
Depth - 55mm
Brass Internals

Style - Traditional
Type - Angled Thermostatic
Valve Inlet - 15mm compression
Radiator Coupler - 1/2" BSPT male thread
Feature - Frost Protection
Reversible
Comprises of One wheel-head and one lock-shield
We recommend that:
TRV wheel head is connected to the flow
Lock shield valve is connected to the return

CAMDEN THERMO ANGLED RADIATOR VALVES ANTQ B RAD/870/B



Traditional TRV

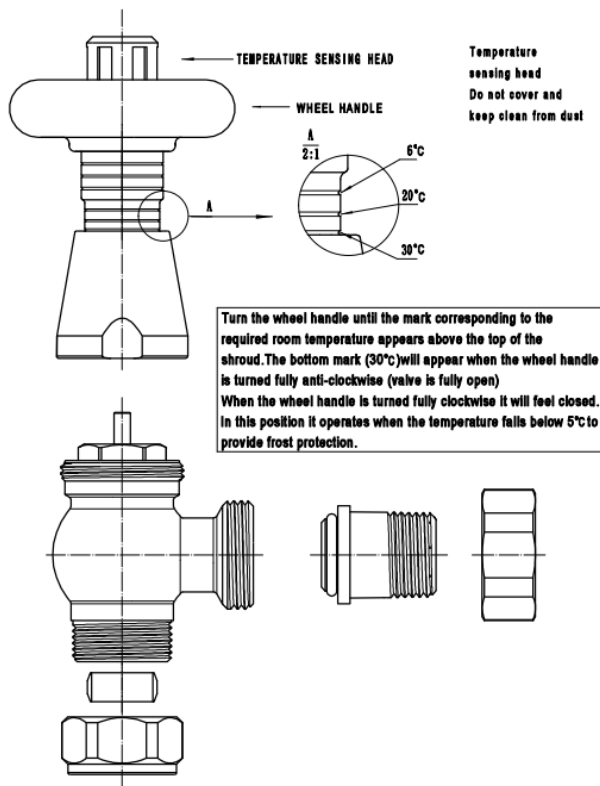

Traditional TRV

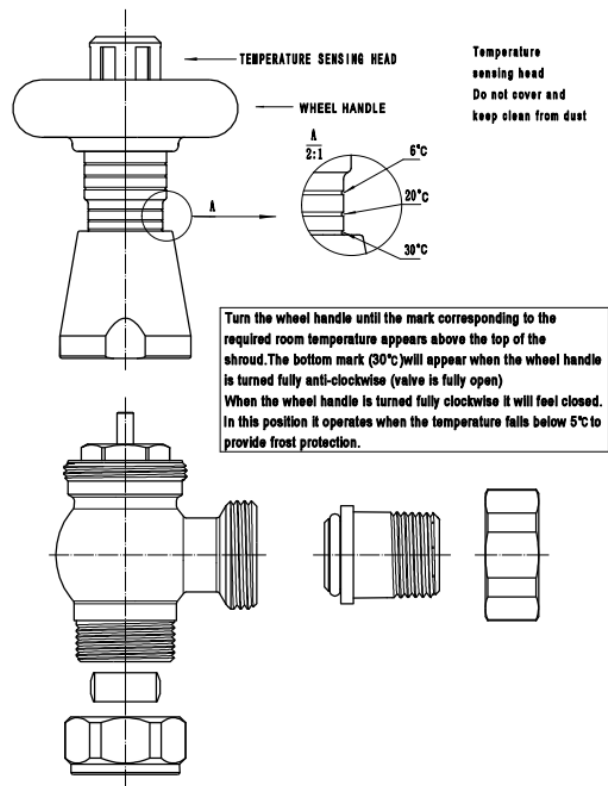

The information contained on this page was correct at the date of issue. Fitting dimensions are provided as a guide only. Some variation may occur due to manufacturing tolerances. We pursue a policy of continuing improvement in design and performance of our products and so reserve the right to change specifications without prior notice

FOR FURTHER ADVICE PLEASE CONTACT :-

SAGITTARIUS LTD UNIT 1 LOWER VICTORIA STREET—CHADDERTON—OLDHAM—OL9 9TU TEL:0616 6202029

EMAIL:TECHNICAL@SAGITTARIUSTAPS.CO.UK