

SAGITTARIUS

TAPS & SHOWERING

Construction	Brass Body (CuZn40Pb2), EN CW617N (equivalent to BS CZ122) Zinc-alloy Handle
Finishes	Chrome plated to BS EN 248
Product Type	Contemporary
Water Pressure Tested Between	Min. 0.2 bar, Max. 5.0 bar
Standards	Complies with BS6920, BS EN200
Certification	-
Cartridge	35mm Ceramic disc cartridge
Net Weight (Tap only)	509g
Aerator	M24*1 Spout aerator
Fitting	UK: M10 x 350mm G1/2" BSP Female Flexi Tails EU: M10 x 350mm G3/8" BSP Female Flexi Tails
Guarantee	10 years against manufacturing faults (excluding serviceable parts)
Additional Information	Supplied with G1¼" sprung waste (UK only)

PRESTIGE CONTRACT BASIN MIXER CHROME PE/106/C

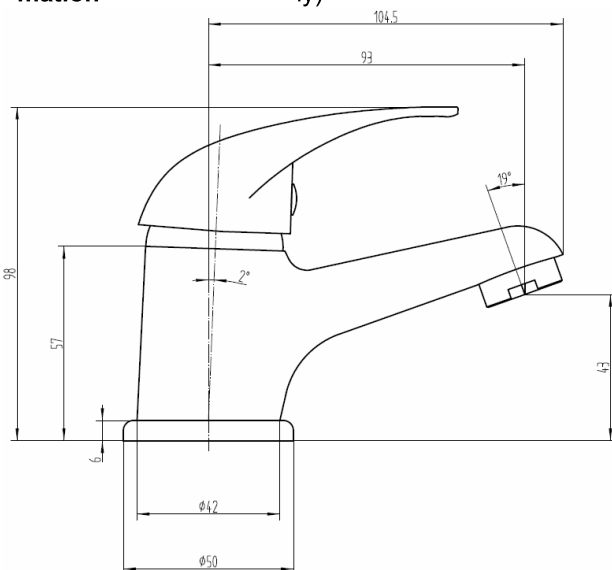

The information contained on this page was correct at the date of issue. Fitting dimensions are provided as a guide only. Some variation may occur due to manufacturing tolerances. We pursue a policy of continuing improvement in design and performance of our products and so reserve the right to change specifications without prior notice

FOR FURTHER ADVICE PLEASE CONTACT :-

SAGITTARIUS LTD UNIT 1 LOWER VICTORIA STREET—CHADDERTON—OLDHAM—OL9 9TU TEL:0616 6202029

EMAIL:TECHNICAL@SAGITTARIUSTAPS.CO.UK

Flow Rates (Litres per minute)

System Pressure	0.1 Bar	0.2 Bar	0.3 Bar	0.5 Bar	1.0 Bar	1.5 Bar	2.0 Bar	3.0 Bar	4.0 Bar	5.0 Bar
	1.2	3.8	-	7.1	10.4	13.0	16.8	18.1	-	-

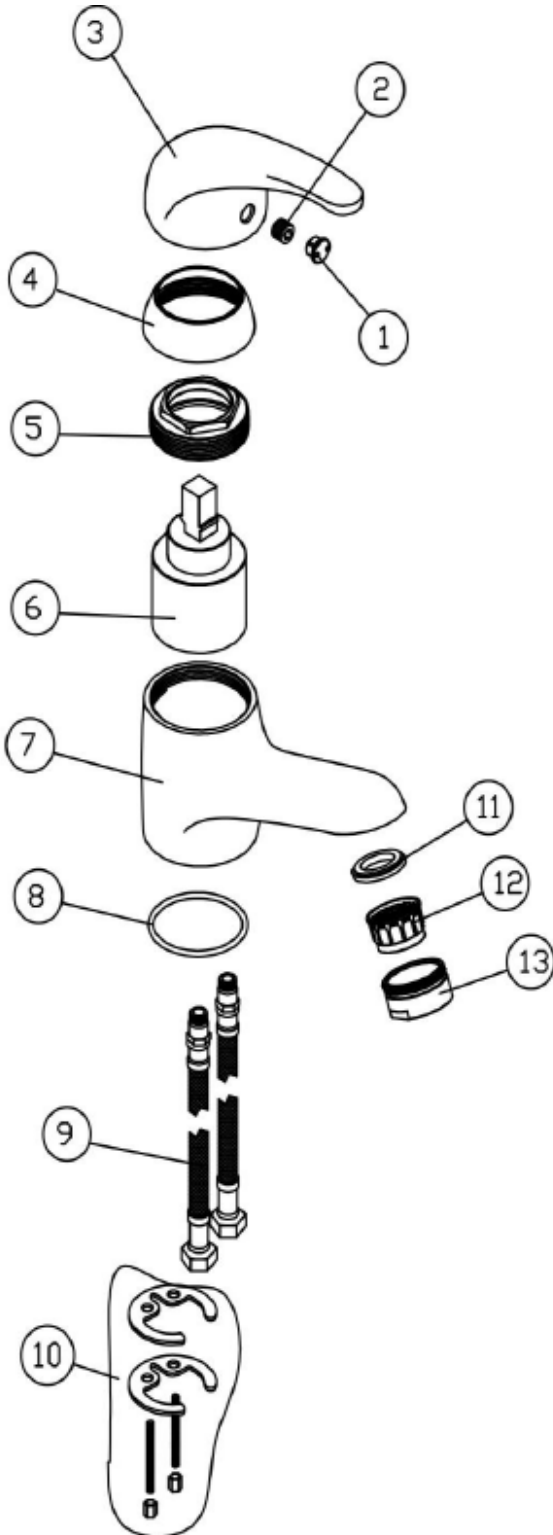

Basin Mono

No.	Code	Description	Qty
1	V05-01	Plastic Badge	1
2	V05-02	M5*6 Screw	1
3	V05-03	Handle	1
4	V05-04	Plastic Cover	1
5	V05-05	Cartridge Cover	1
6	V05-06	35mm Cartridge	1
7	V05-07	Body	1
8	V05-08	38*2.5 O-Ring	1
9	V05-09	M10*1*350 Flexible Pipe	2
10	V05-10	M6 Fixing Sets	1
11	V05-11	22.8*16*2 Rubber Washer	1
12	V05-12	Aerator	1
13	V05-13	M24*1 Nozzle	1

FOR FURTHER ADVICE PLEASE CONTACT :-

SAGITTARIUS LTD UNIT 1 LOWER VICTORIA STREET—CHADDERTON—OLDHAM—OL9 9TU TEL:0616 6202029

EMAIL:TECHNICAL@SAGITTARIUSTAPS.CO.UK