

SAGITTARIUS

TAPS & SHOWERING

NAPLES CLOAKROOM MINI MONO BLOC BASIN MIXER

NA/186

Construction	Brass Body, Zinc-alloy Handle
Finishes	Chrome plated to BS EN 248
Product Type	Contemporary
Water Pressure Tested Between	Min. 0.2 bar, Max. 6.0 bar
Standards	Complies with BS6920, BS EN200
Net Weight (Tap only)	660g
Cartridge	30mm Ceramic disc cartridge
Aerator	Laminar spout
Fitting	UK: M10 x 350mm G1/2" BSP Female Flexi Tails EU: M10 x 350mm G3/8" BSP Female Flexi Tails
Guarantee	10 years against manufacturing faults (excluding serviceable parts)
Additional Information	Supplied with G1¼" sprung waste (UK only)

Operating Water Pressure



LOW PRESSURE
0.2 - 0.5 bar



COMBI BOILER



HIGH PRESSURE
1.2 - 1.5+ bar

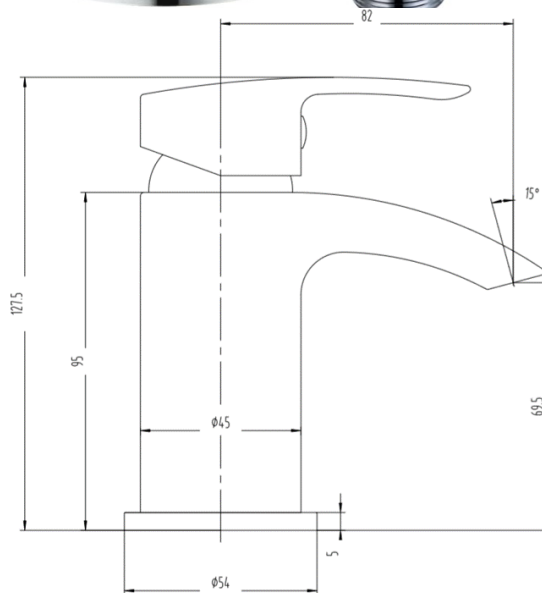

The information contained on this page was correct at the date of issue. Fitting dimensions are provided as a guide only. Some variation may occur due to manufacturing tolerances. We pursue a policy of continuing improvement in design and performance of our products and so reserve the right to change specifications without prior notice

FOR FURTHER ADVICE PLEASE CONTACT :-

SAGITTARIUS LTD UNIT 1 LOWER VICTORIA STREET—CHADDERTON—OLDHAM—OL9 9TU TEL:0616 6202029

EMAIL:TECHNICAL@SAGITTARIUSTAPS.CO.UK

Flow Rates (Litres per minute)

System Pressure	0.1 Bar	0.2 Bar	0.3 Bar	0.5 Bar	1.0 Bar	1.5 Bar	2.0 Bar	3.0 Bar	4.0 Bar	5.0 Bar
	2.3	4.1	-	6.5	9.4	11.5	13.3	16.5	-	-

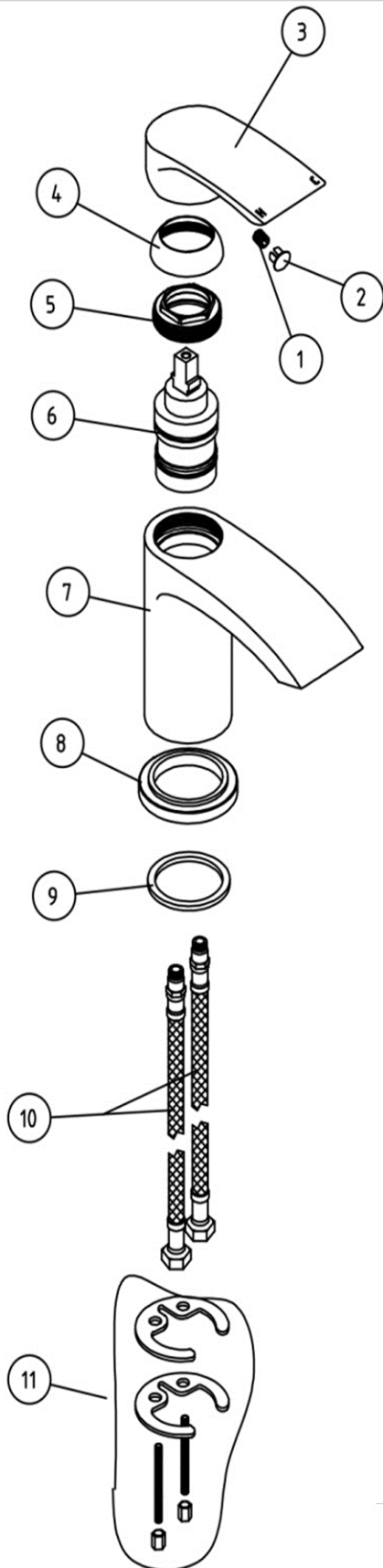

NO.	DESCRIPTION	QTY
1	M5*6 SCREW	1
2	HANDLE COVER	1
3	HANDLE	1
4	CARTRIDGE COVER	1
5	CARTRIDGE NUT	1
6	35MM UP-SEAL CARTRIDGE	1
7	TAP BODY	1
8	54 BASE PLATE	1
9	46*38*2.5 WASHER	1
10	M10*1*400 FLEXI TAILS	2
11	M6 FIXING KIT	1