

SAGITTARIUS

TAPS & SHOWERING

Construction	Brass Body, Zinc alloy Handle
Finishes	Chrome (Ni : 8-12um, Cr : 0.25-0.3um)
Product Type	Contemporary
Water Pressure Tested	Min. 0.2 bar,
Standards	Complies with BS6920, BS EN200
Certification	WRAS (1710044) approved and certified
Cartridge	35mm Coldstart Ceramic disc cartridge
Aerator	Neoperl Adjustable Slim Aerator
Fitting	UK: M10 x 350mm G1/2" BSP Female Flexi Tails EU: M10 x 350mm G3/8" BSP Female Flexi Tails
Guarantee	10 years against manufacturing faults (excluding serviceable parts)
Additional Information	Supplied with G1¼" sprung waste (UK)
Operating Water Pressure	

METRO MONO BLOC BASIN MIXER

MT/106

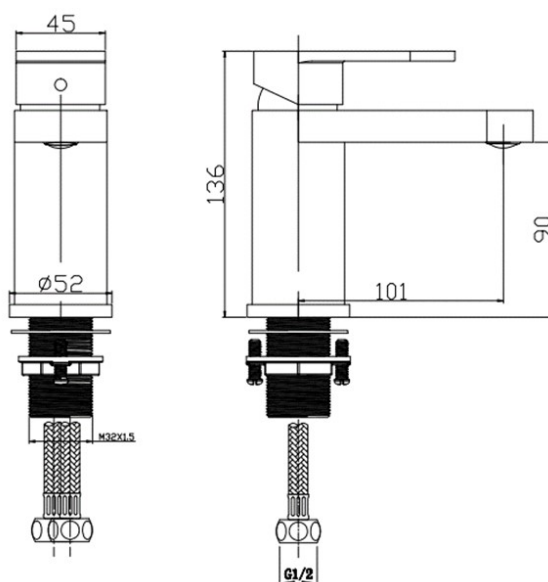

LOW PRESSURE

0.2- 0.5 bar



COMBI BOILER



HIGH PRESSURE

1.2- 1.5+ bar

The information contained on this page was correct at the date of issue. Fitting dimensions are provided as a guide only. Some variation may occur due to manufacturing tolerances. We pursue a policy of continuing improvement in design and performance of our products and so reserve the right to change specifications without prior notice

FOR FURTHER ADVICE PLEASE CONTACT :-

SAGITTARIUS LTD UNIT 1 LOWER VICTORIA STREET—CHADDERTON—OLDHAM—OL9 9TU TEL:0616 6202029

EMAIL:TECHNICAL@SAGITTARIUSTAPS.CO.UK

Flow Rates (Litres per minute)

System Pressure	0.1 Bar	0.2 Bar	0.3 Bar	0.5 Bar	1.0 Bar	1.5 Bar	2.0 Bar	3.0 Bar	4.0 Bar	5.0 Bar
	2.7	4.0	5.0	6.3	8.8	10.6	12.3	14.9	17.1	19.0

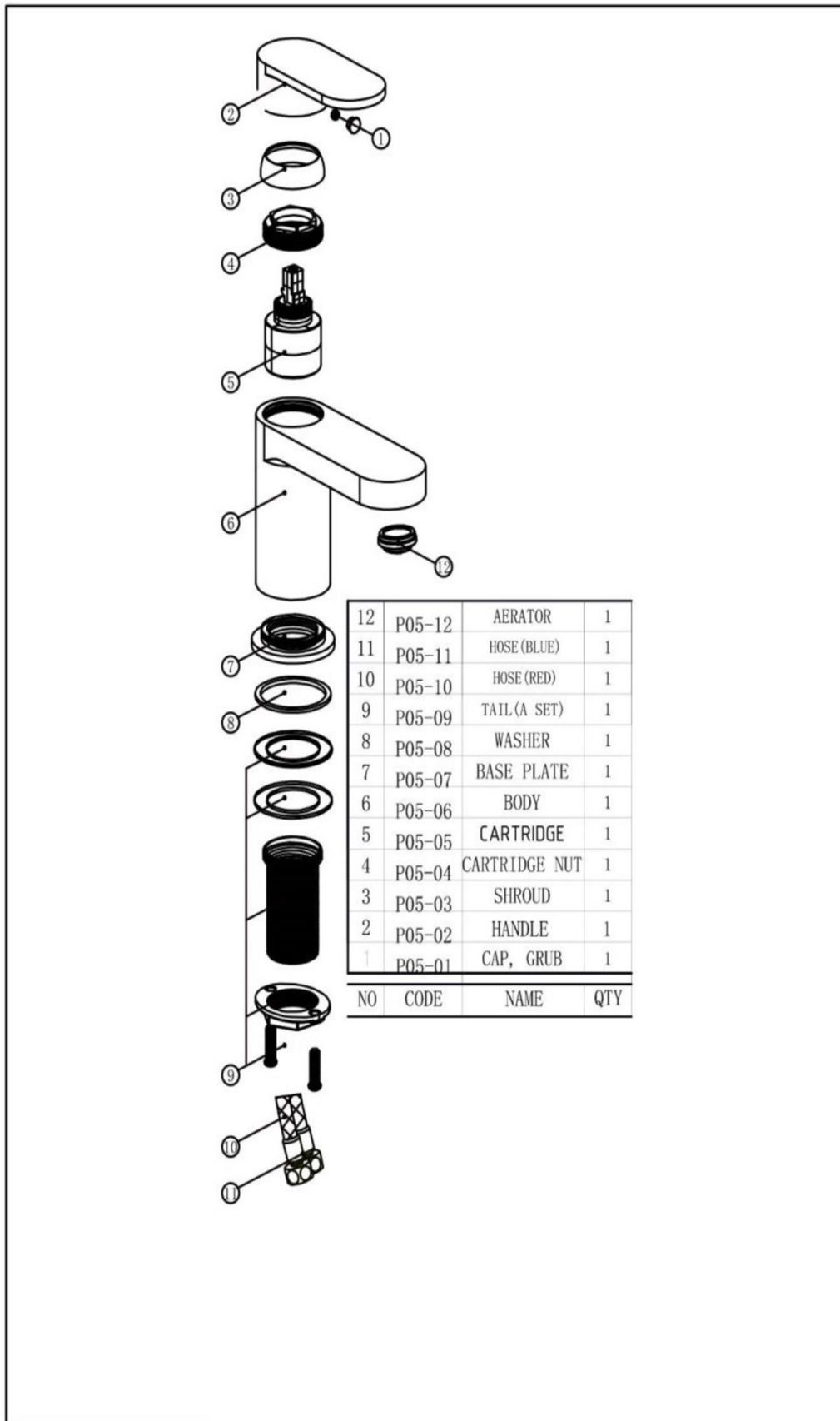

FOR FURTHER ADVICE PLEASE CONTACT :-

SAGITTARIUS LTD UNIT 1 LOWER VICTORIA STREET—CHADDERTON—OLDHAM—OL9 9TU TEL:0616 6202029

EMAIL:TECHNICAL@SAGITTARIUSTAPS.CO.UK