

# SAGITTARIUS

## TAPS & SHOWERING

### CONTRACT MONOBLOC SINK MIXER KTS/239/C

<b>Construction</b>	Brass Body (CuZn40Pb18); Zinc- alloy Handles
<b>Finishes</b>	Chrome plated to BS EN 248
<b>Product Type</b>	Contemporary
<b>Water Pressure Tested Between Standards</b>	Min. 0.2 bar, Max. 6.0 bar Complies with BS5412, BS EN200
<b>Cartridge</b>	1/4 Turn 1/2" Ceramic Disc Valves
<b>Fitting</b>	10mm G1/2" BSP Flex- ible inlet connection hoses
<b>Aerator Guarantee</b>	Spout aerator 10 years against manu- facturing faults (excluding serviceable parts)



Water pressure

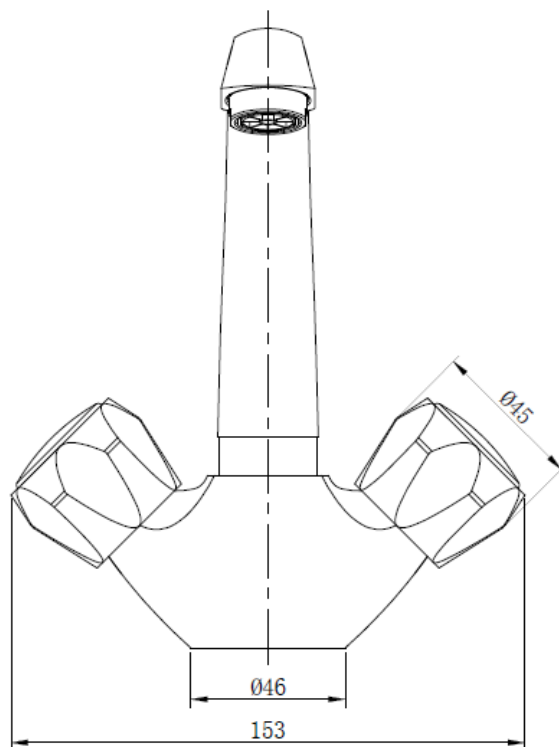
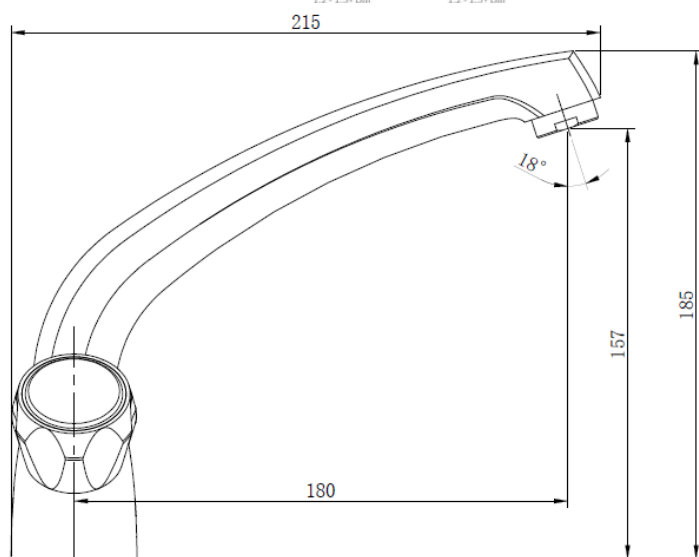

The information contained on this page was correct at the date of issue. Fitting dimensions are provided as a guide only. Some variation may occur due to manufacturing tolerances. We pursue a policy of continuing improvement in design and performance of our products and so reserve the right to change specifications without prior notice

FOR FURTHER ADVICE PLEASE CONTACT :-

SAGITTARIUS LTD UNIT 1 LOWER VICTORIA STREET—CHADDERTON—OLDHAM—OL9 9TU TEL:0616 6202029

EMAIL:TECHNICAL@SAGITTARIUSTAPS.CO.UK

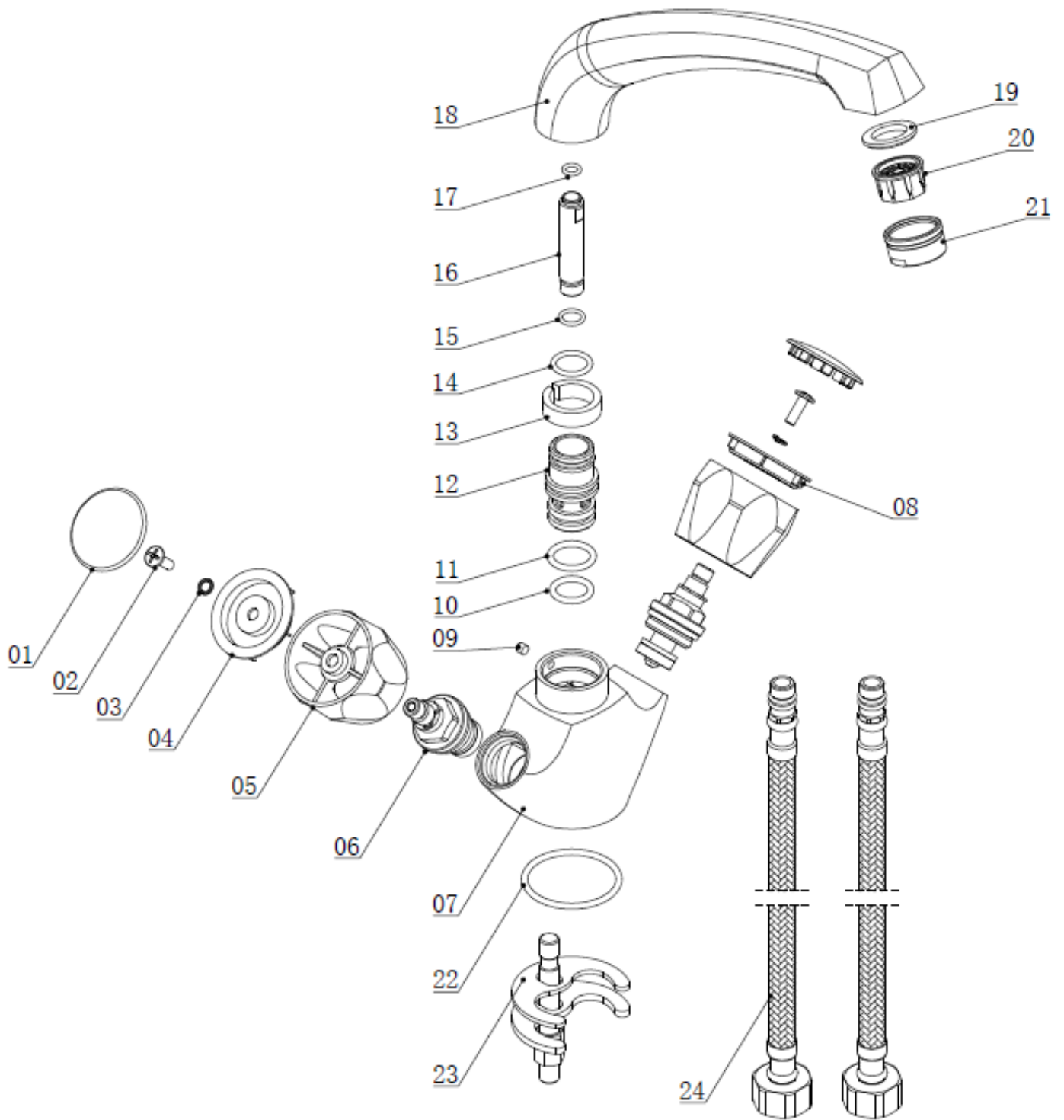

FOR FURTHER ADVICE PLEASE CONTACT :-

SAGITTARIUS LTD UNIT 1 LOWER VICTORIA STREET—CHADDERTON—OLDHAM—OL9 9TU TEL:0616 6202029

EMAIL:TECHNICAL@SAGITTARIUSTAPS.CO.UK