

SAGITTARIUS

TAPS & SHOWERING

Construction	Brass Body (CuZn40Pb18); Zinc-alloy Handles
Finishes	Brushed Nickel
Product Type	Contemporary
Water Pressure Tested Between	Min. 0.5 bar, Max. 6.0 bar
Plumbing Systems	Suitable for all plumbing systems, Hot and Cold water pressure preferably balanced Max. supply pressure differential requirement no greater than 5:1
Standards	Complies with BS5412, BS EN200
Certification	Manufactured to comply with WRAS
Cartridge	1/4 Turn 1/2" Ceramic disc valves
Aerator	Spout aerator
Fitting	G1/2" BSP Female Flexible inlet connection hoses
Guarantee	10 years against manufacturing faults (excluding serviceable parts)
Additional Information	360° Swivel Spout

**KINETIC MONOBLOC SINK
MIXER BRUSHED NICKEL
KTS/232/BN**

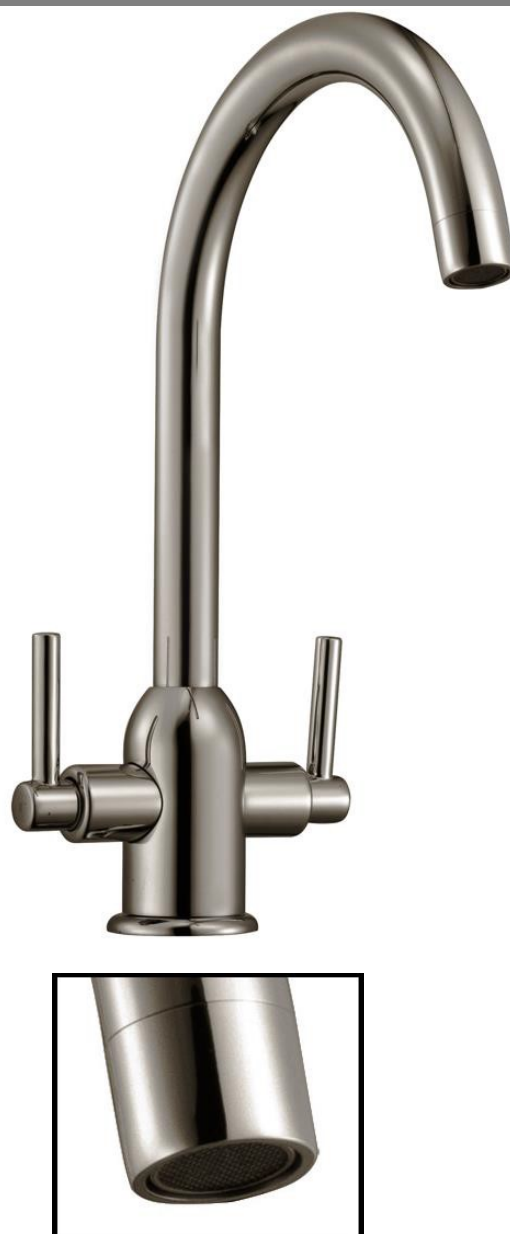
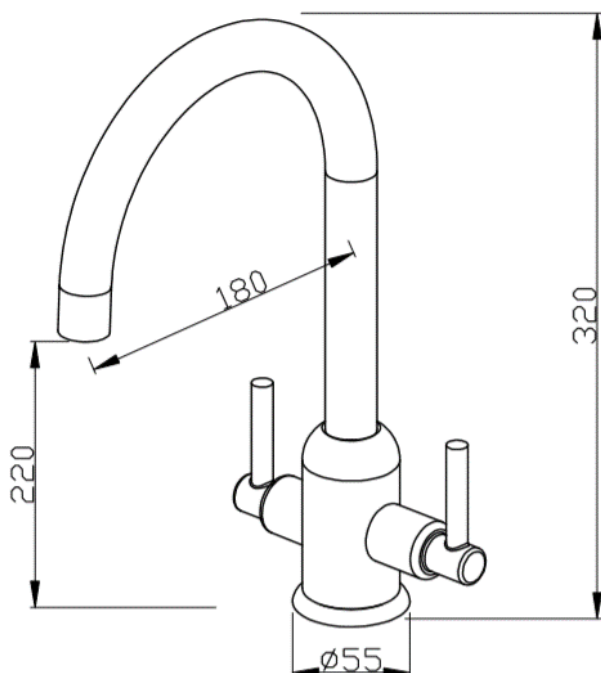

The information contained on this page was correct at the date of issue. Fitting dimensions are provided as a guide only. Some variation may occur due to manufacturing tolerances. We pursue a policy of continuing improvement in design and performance of our products and so reserve the right to change specifications without prior notice

FOR FURTHER ADVICE PLEASE CONTACT :-

SAGITTARIUS LTD UNIT 1 LOWER VICTORIA STREET—CHADDERTON—OLDHAM—OL9 9TU TEL:0616 6202029

EMAIL:TECHNICAL@SAGITTARIUSTAPS.CO.UK

Flow Rates (Litres per minute)

System Pressure	0.1 Bar	0.2 Bar	0.3 Bar	0.5 Bar	1.0 Bar	1.5 Bar	2.0 Bar	3.0 Bar	4.0 Bar	5.0 Bar
	-	4.0	-	6.8	9.5	-	14.0	17.0	-	-

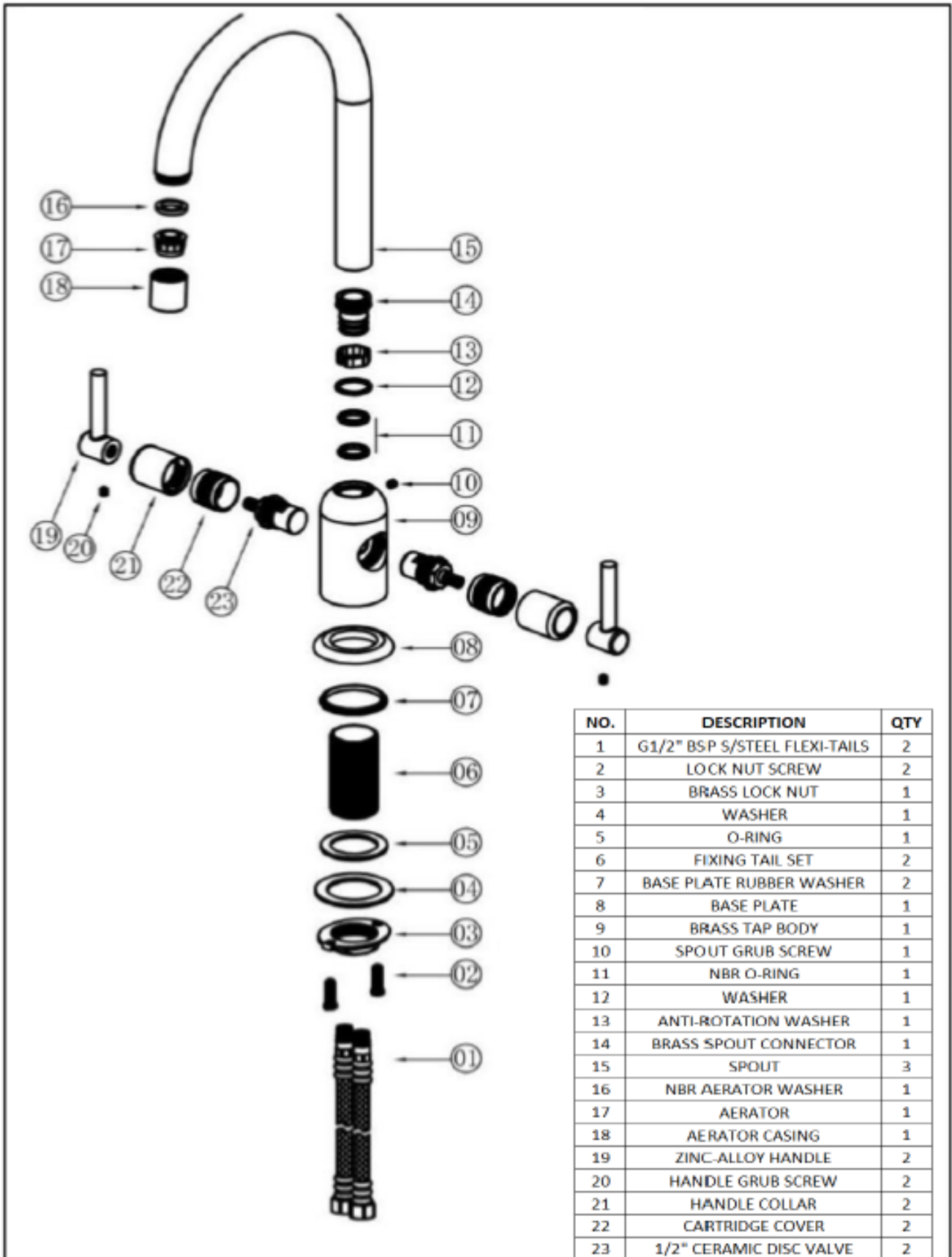

NO.	DESCRIPTION	QTY
1	G1/2" BSP S/STEEL FLEXI-TAILS	2
2	LOCK NUT SCREW	2
3	BRASS LOCK NUT	1
4	WASHER	1
5	O-RING	1
6	FIXING TAIL SET	2
7	BASE PLATE RUBBER WASHER	2
8	BASE PLATE	1
9	BRASS TAP BODY	1
10	SPOUT GRUB SCREW	1
11	NBR O-RING	1
12	WASHER	1
13	ANTI-ROTATION WASHER	1
14	BRASS SPOUT CONNECTOR	1
15	SPOUT	3
16	NBR AERATOR WASHER	1
17	AERATOR	1
18	AERATOR CASING	1
19	ZINC-ALLOY HANDLE	2
20	HANDLE GRUB SCREW	2
21	HANDLE COLLAR	2
22	CARTRIDGE COVER	2
23	1/2" CERAMIC DISC VALVE	2

FOR FURTHER ADVICE PLEASE CONTACT :-

SAGITTARIUS LTD UNIT 1 LOWER VICTORIA STREET—CHADDERTON—OLDHAM—OL9 9TU TEL:0616 6202029

EMAIL:TECHNICAL@SAGITTARIUSTAPS.CO.UK