

# SAGITTARIUS

## TAPS & SHOWERING

<b>Construction</b>	Brass Body (CuZn40Pb2), EN CW617N (equivalent to BS CZ122)
<b>Finishes</b>	Chrome plated to BS EN 248
<b>Product Type</b>	Hands free infrared activation commercial Tap
<b>Water Pressure Tested Between</b>	Min. 1.5 bar, Max. 6.0 bar
<b>Certification</b>	CE, ROHS, IP54, WRAS (Pending)
<b>Power</b>	Voltage: DC6V or AC220V-240V (6V Output); Dynamic Output Power: 3V; Working Voltage of Solenoid Valve: 4.5V
<b>Power Options</b>	Choice of :  Batteries only DC (4 x AA batteries: up to 2 years lifespan depend on level of usage)  Mains power AC supply only  Both Mains AC + Batteries DC (backup) connected at the same time
<b>Power Consumption</b>	Less than 1W (DC) or 0.2mW (AC); Silent power consumption: 0.5mW
<b>Fitting</b>	Control box: Diameter of 'inlet' pipe: G1/2" BSP  Control box: Diameter of 'outlet' pipe: G1/2" BSP Suitable for cold or pre-mixed water
<b>Sensing distance</b>	6 - 24 cm (Factory setting to 17-18 cm)
<b>Respond time</b>	0.3 Second
<b>Aerator</b>	Spout aerator (Anti splash & flow restrictor)
<b>Max operational temperature</b>	Maximum operational temperature 45°C
<b>Additional Information</b>	Suitable for cold or premixed water, and suitable for main or battery installation  This tap is compatible with our UT11 IRC Sensor Remote Control (Sold separately)  It's entirely up to customer to decide which power option/combination suits your installation / usage the best. The integrity of the tap stays the same.

### INFRA RED BASIN MIXER CHROME IR/069/C



The information contained on this page was correct at the date of issue. Fitting dimensions are provided as a guide only. Some variation may occur due to manufacturing tolerances. We pursue a policy of continuing improvement in design and performance of our products and so reserve the right to change specifications without prior notice

FOR FURTHER ADVICE PLEASE CONTACT :-

SAGITTARIUS LTD UNIT 1 LOWER VICTORIA STREET—CHADDERTON—OLDHAM—OL9 9TU TEL:0616 6202029

EMAIL:TECHNICAL@SAGITTARIUSTAPS.CO.UK

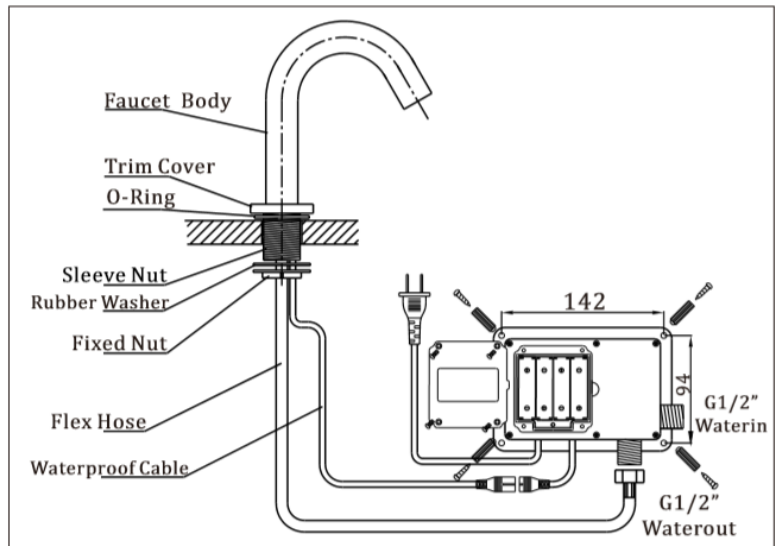
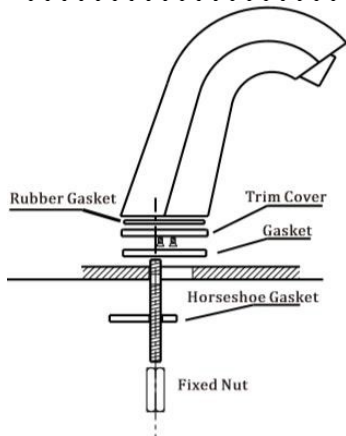
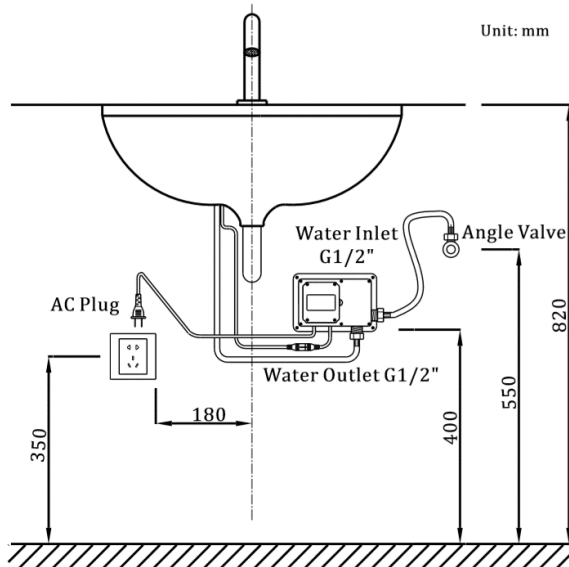
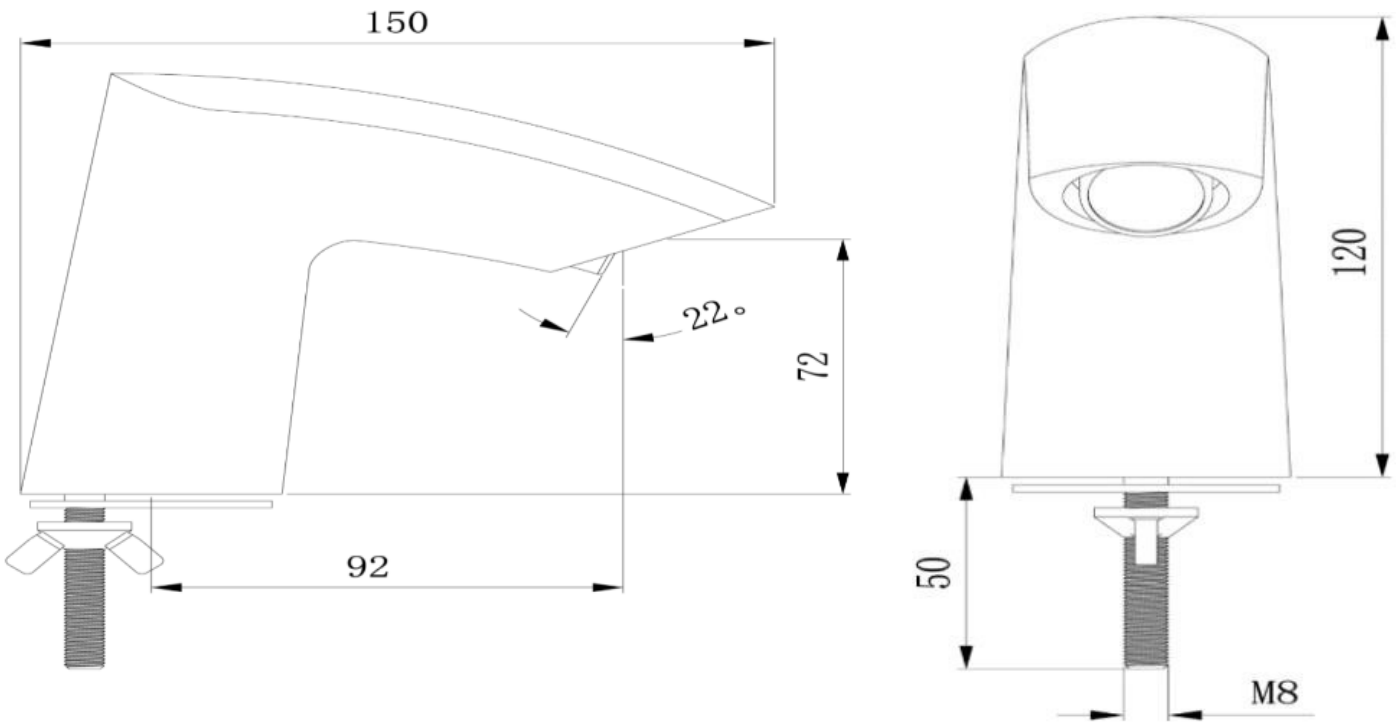

**Flow Rates (Litres per minute)**

System Pressure	0.1 Bar	0.2 Bar	0.3 Bar	0.5 Bar	1.0 Bar	1.5 Bar	2.0 Bar	3.0 Bar	4.0 Bar	5.0 Bar
	-	-	-	1.6	2.5	-	3.6	4.4	5.0	5.6

FOR FURTHER ADVICE PLEASE CONTACT :-  
 SAGITTARIUS LTD UNIT 1 LOWER VICTORIA STREET—CHADDERTON—OLDHAM—OL9 9TU TEL:0616 6202029  
 EMAIL:TECHNICAL@SAGITTARIUSTAPS.CO.UK