

# SAGITTARIUS

## TAPS & SHOWERING

### ERGO MINI THERMO SHOWER VALVE CHROME EL/169/C



#### GENERAL CHARACTERISTICS

The shower Mixer is suitable for all water heating systems provided it is installed correctly.

Please refer to installation diagram.

#### OPERATING SPECIFICATIONS

##### Hot water supply temperature

Maximum: 85°C Higher than maximum required mixer temperature.

Advisable: 65°C

Minimum: 5° C

Minimum difference between hot and mixed temperature is 10°C.

##### Operating Pressure

Maximum: 5 Bar

Minimum: 0.1 Bar



Hot and Cold Operating pressure should be kept as balanced as possible in order to maintain maximum efficiency.

When the supply pressure is higher than a 5 Bar a pressure reducing valve should be fitted before the shower valve.

#### TECHNICAL DATA

The temperature control knob is pre-set at 38°C

The mixer inlets can be supplied with threads: G ½" BSP

The valve is provided with one outlet (top)

#### PLUMBING RECOMMENDATIONS

- An independent hot and cold water supply is required for the shower system (do not pipe off ring main) please refer to installation diagrams.
- Large runs of pipe work will cause frictional loss of pressure.
- The recommended pipe work from both cylinder and water tank should be 22mm minimum for low-pressure systems.
- If more than one shower valve is installed the minimum feed from tank and cylinder should be 28mm. (Ensure adequate supply of both hot and cold water can be maintained).
- In installations where a pump is required, install pump before shower mixer inlets

#### WATER BYE LAWS

The mixing valve should be installed in accordance with the water bye laws. For further details refer to the latest copy of Water Bye Laws guide or your local water authority.

The information contained on this page was correct at the date of issue. Fitting dimensions are provided as a guide only. Some variation may occur due to manufacturing tolerances. We pursue a policy of continuing improvement in design and performance of our products and so reserve the right to change specifications without prior notice

FOR FURTHER ADVICE PLEASE CONTACT :-

SAGITTARIUS LTD UNIT 1 LOWER VICTORIA STREET—CHADDERTON—OLDHAM—OL9 9TU TEL:0616 6202029

EMAIL:TECHNICAL@SAGITTARIUSTAPS.CO.UK

## INSTALLATION

Before installation, read the instructions.

Installation must be performed by qualified and competent staff.

**The hot water inlet must be on the left side of the mixer. Red mark on body valve.**

- Plumb the hot and cold water pipes and mixed water outlet to the desired mixer position. Please refer to the dimensional drawing showing the position of the mixer inlets, outlet and how to determine the centre of the mixer wall mounting plate.
- Consider the thickness of the final coating (tiles, marble, etc)
- Keep a 84 mm hole in the wall to remove the protection and for the future maintenance of the product.
- Place the mixer in the correct position and mark the fixing holes.
- Drill the fixing holes in the wall  $\text{Ø}6$  and insert the four wall plugs (1).
- Place the mixer and fit the four screw (2)
- Insert the copper pipe in the inlet and the outlet seat. Fit the inlet and outlet connections fittings to the ends of the pipe work. Connections not supplied.
- Keep the plastic cover on the outside of the mixer body to prevent damage during installation.
- Remove the plastic cover from the mixer body and fit the front cover plate (3).
- Fit the on/off control lever (4) to the outer on/off control ring.

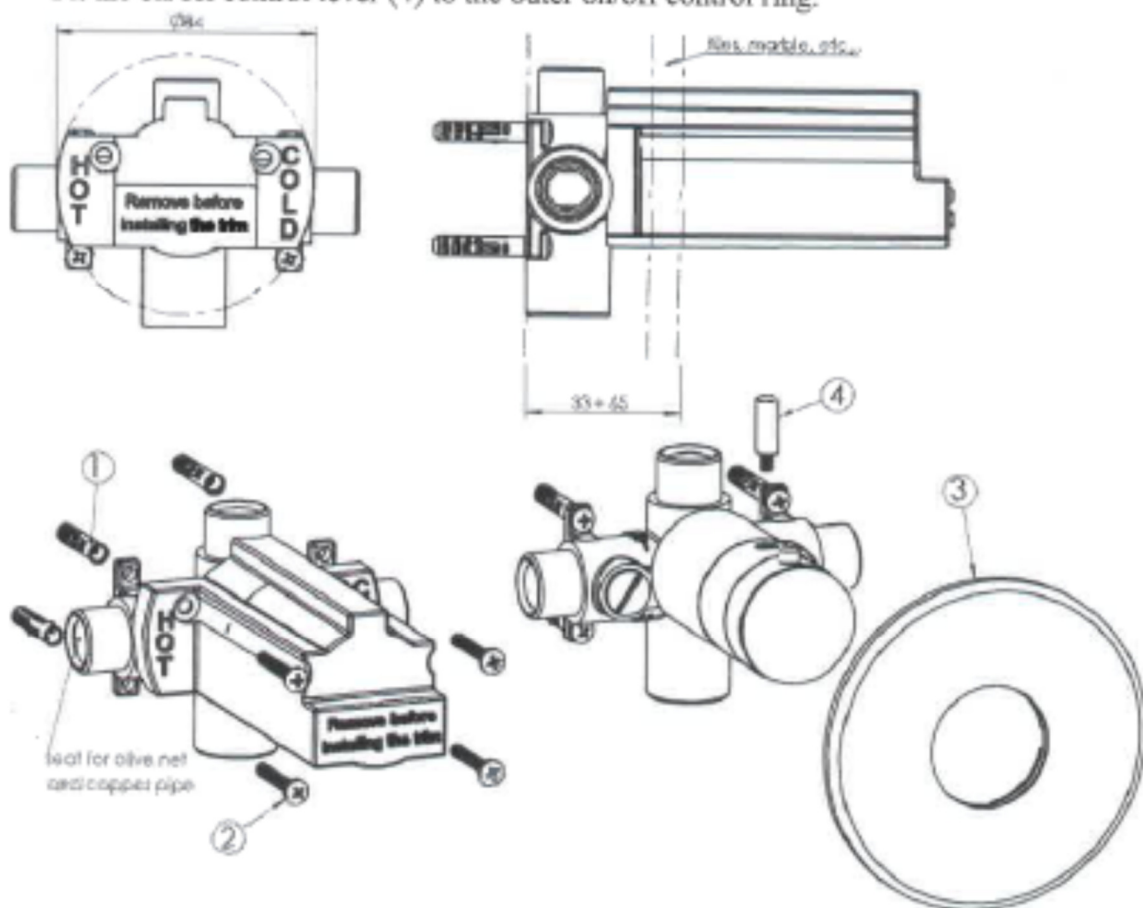

## CARTRIDGE CHANGE AND CLEANING

Through years of use impurities and limescale could restrict flow of water through the filters of the cartridge.

To clean it follow the instructions hereunder :

- Shut off water supply to both inlets.
- Remove the cap (1) and the grub screw (2) with an allen key 2 mm and take off the temperature control knob (3).
- Remove the Teflon ring (4), remove the plastic stop (5) and remove the Teflon ring (6).
- Remove the lever (7), the grub screws (8) and (9) with an allen key 2 mm and take off the closure ring (10).
- Remove the Teflon ring (11).
- Unscrew the flange (12) with a 32 mm wrench, and remove the cartridge (13):
- Wash the filters under running water or leave to soak in vinegar or de-scaling agent.
- Follow the above instructions in reverse order for assembly.
- Re-assemble the plastic stop (5) according to the drawing and turn spindle (A) until you reach required temperature 38°C.

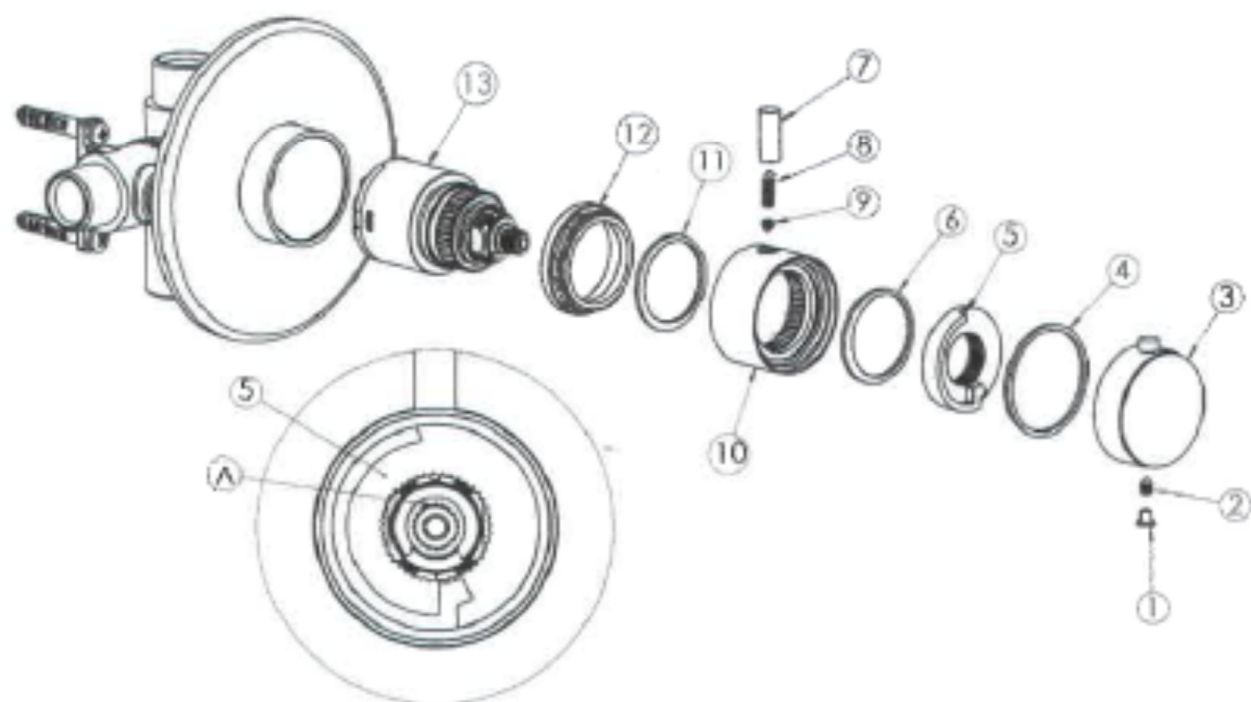

## FILTER CLEANING

Through years of use impurities and limescale could restrict flow of water through the filters  
To clean it follow the instructions hereunder:

- Shut off water supply to both inlets.
- Unscrew the lever (1) and the grub screws (2) with an Allen key 2 mm.
- Remove the cover plate (3).
- Unscrew the two filter caps (4).
- Remove the filter (5).
- Wash filters under running water or leave them to soak in vinegar or de-scaling agent.
- Follow the above instructions in reverse order for assembly.

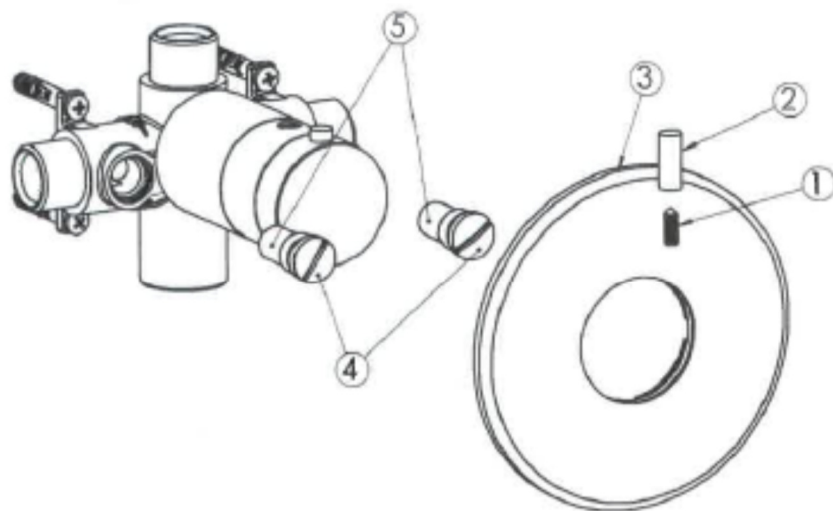

## TROUBLESHOOTING

### 1) REDUCED FLOW RATE

*Cause:* The inlet filters of the mixer and/or the cartridge are obstructed.

*Solution:* Cleaning filters and/or cartridge: refer to "CARTRIDGE CHANGE AND CLEANING"

Cleaning mixer filters: refer to "FILTER CLEANING"

### 2) WRONG SETTING OF THE CARTRIDGE

*Causes:* The mixer is factory preset at 2,5-3 bar and at a temperature of 60-65°C for hot water and 10-15°C for the cold one corresponding to a mixing temperature of 38°C. In every domestic installation temperatures and inlets pressures can differ from those of production.

*Solutions:* Take the water temperature, using a common thermometer for domestic use

Remove the temperature control handle

Turn the broached ring of the cartridge until the blended water reaches the desired temperature

Re-assemble the temperature control handle.

### 3) CONTINUOUS TEMPERATURE OSCILLATIONS

*Cause:* The mixer has been installed with the inverted inlets

*Solution:* Close the main water supply

Remove the valve body: refer to "FILTER CLEANING"

Rotate the valve body reverse the outlet

Re-install the valve body

### 4) INCORRECT WORKING OF THE MIXING

*Cause:* The filters of the cartridge are dirty

*Solution:* Refer to the "CARTRIDGE CHANGE AND CLEANING"

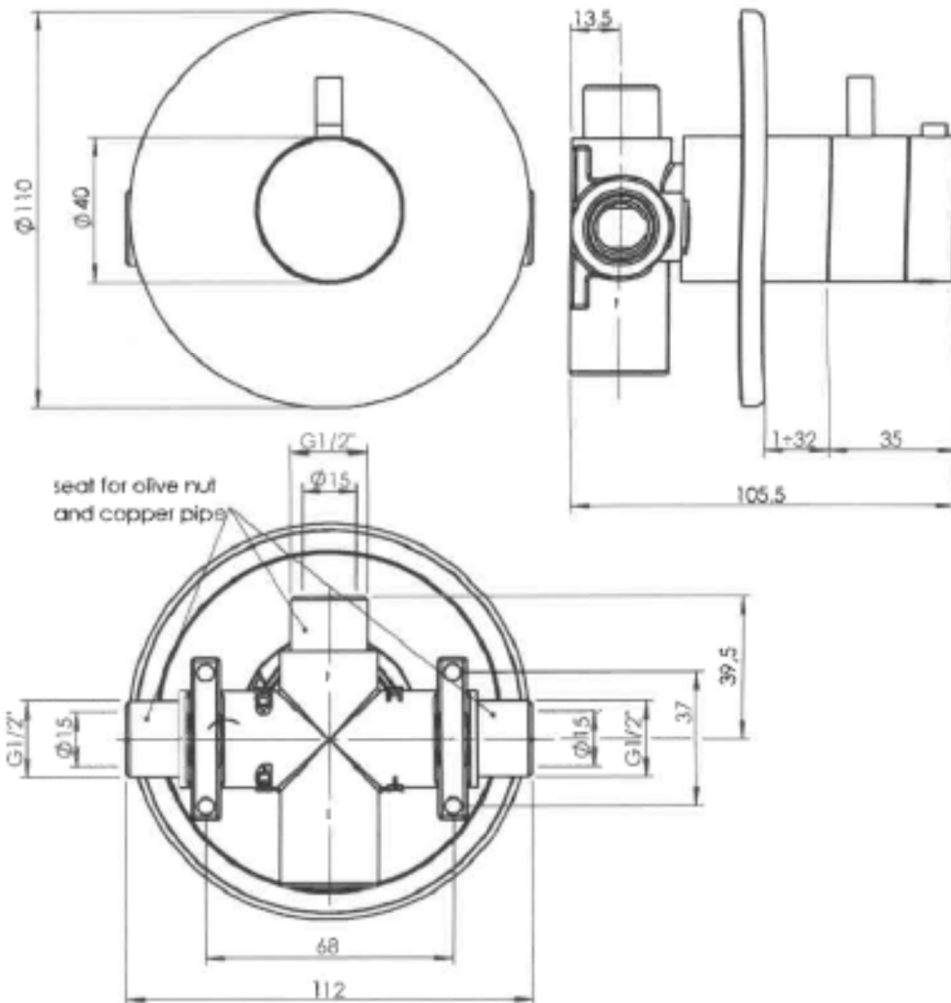

### IMPORTANT – CARE OF YOUR PRODUCT CLEANING

After use all finishes should be maintained by wiping with a soft, damp, clean cloth and then polished using a dry duster. NO abrasive powder, detergents or polishes should be used. Cleaner containing alcohol, acid or corrosive chemicals should not be used.

### NOTE

- ◆ Some household bleaches and denture cleaners can damage plated or coloured finishes and if splashed onto a fitting should be immediately washed off with cold water.
- ◆ If these instructions are followed we believe this fitting will give many years of satisfactory use.
- ◆ We have a policy of continuous improvement and reserve the right to change specification without notice.
- ◆ In case of prolonged disuse of the mixer in winter time, it is recommended to close the system and empty the mixer to avoid damages caused by frost.

### GUARANTEE

This shower mixer is guaranteed for a period of 5 years against any defects of materials and workmanship from date of purchase, subject to correct installation, maintenance and use in accordance with this instruction leaflet. Please retain proof of purchase.

During the guarantee period parts will be replaced or repaired at our option. No labour costs will be reimbursed unless prior agreement has been obtained from the factory in writing.

This guarantee is offered as an extra benefit and does not affect your statutory rights as a consumer in any way whatsoever.