

SAGITTARIUS

TAPS & SHOWERING

Construction	Brass Body, Zinc-alloy Handle
Finishes	Brushed Brass
Product Type	Contemporary
Water Pressure Tested	Min. 0.2 bar, Max. 6.0 bar
Standards	Complies with BS6920, BS EN200
Cartridge	CITEC 35mm 110° Turn Cold Start Ce-
Aerator	Neoperl Slim Aerator
Fitting	UK: M10 x 350mm G½" BSP Female Flexi Tails EU: M10 x 350mm G3/8" BSP Female
Guarantee	10 years against manufacturing faults
Additional Information	Supplied with G1¼" sprung waste (UK only)

ERGO Mono Bloc Basin Mixer EL/106/BB



Operating Water Pressure

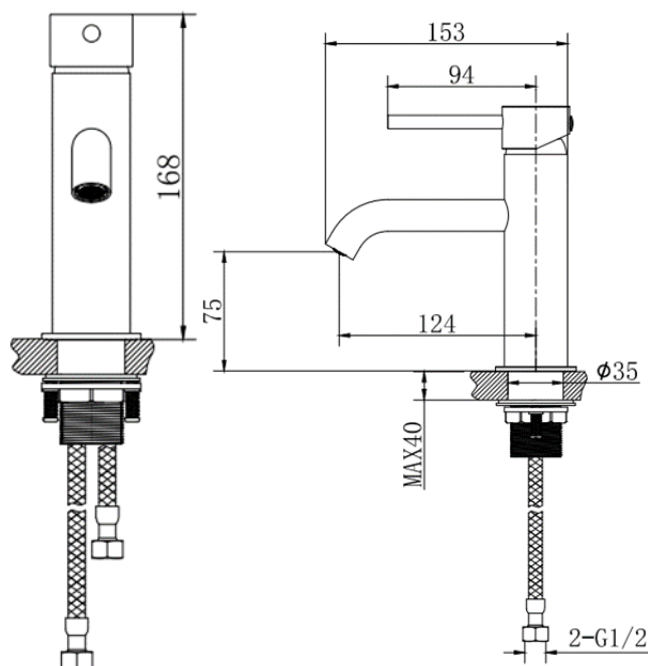
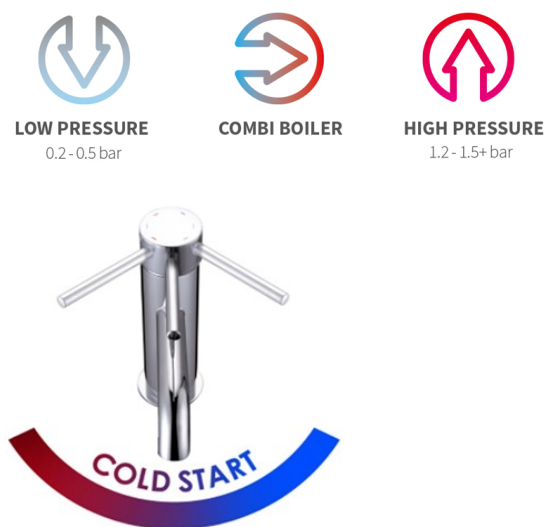

The information contained on this page was correct at the date of issue. Fitting dimensions are provided as a guide only. Some variation may occur due to manufacturing tolerances. We pursue a policy of continuing improvement in design and performance of our products and so reserve the right to change specifications with-

FOR FURTHER ADVICE PLEASE CONTACT :-

SAGITTARIUS LTD UNIT 1 LOWER VICTORIA STREET—CHADDERTON—OLDHAM—OL9 9TU TEL:0616 6202029

EMAIL:TECHNICAL@SAGITTARIUSTAPS.CO.UK

Flow Rates (Litres per minute)

System Pressure	0.1 Bar	0.2 Bar	0.3 Bar	0.5 Bar	1.0 Bar	1.5 Bar	2.0 Bar	3.0 Bar	4.0 Bar	5.0 Bar
	-	-	-	4.6	6.0	-	8.3	10.2	-	-

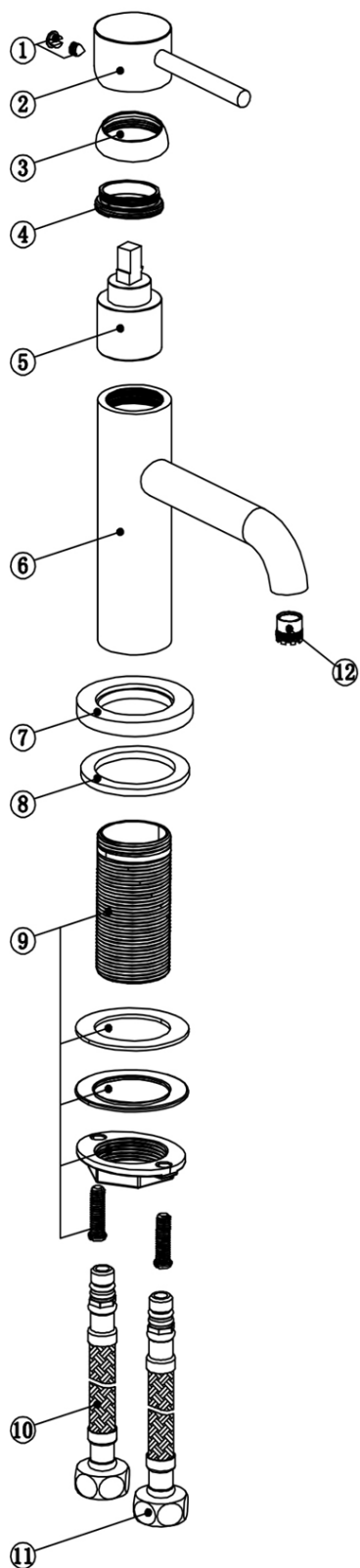

NO.	ITEM	QTY
1	GRUB SCREW & COVER CAP	1
2	ZINC-ALLOY HANDLE	1
3	HANDLE COLLAR	1
4	BRASS CARTRIDGE NUT	1
5	35MM CITEC COLD-START CERAMIC DISC CARTRIDGE	1
6	BRASS TAP BODY	1
7	BASE PLATE	1
8	BASE PLATE WASHER	1
9	BRASS TAP FIXING SET	1
10	G1/2" BSP FLEXI-TAIL (HOT)	1
11	G1/2" BSP FLEXI-TAIL (COLD)	1
12	AERATOR	1

FOR FURTHER ADVICE PLEASE CONTACT :-

SAGITTARIUS LTD UNIT 1 LOWER VICTORIA STREET—CHADDERTON—OLDHAM—OL9 9TU TEL:0616 6202029

EMAIL:TECHNICAL@SAGITTARIUSTAPS.CO.UK