

SAGITTARIUS

TAPS & SHOWERING

EDWARDIAN CONCEALED TWO WAY SHOWER VALVE ED/577

Construction	Brass Body; Ceramic & Zinc-alloy Handle; Brass Wall Plate
Finishes	Chrome plated
Product Type	Contemporary
Water Pressure Tested Between	Min. 0.2 bar, Max. 6.0 bar
Standards	Complies with BSEN 1111
Certification	Manufactured to comply with TMV2
Cartridge	Thermostatic cartridge & Ceramic disc valve
Check valve	0.5-10 gpm (EN1717)
Fitting	Inlet: Two Brass G3/4" BSP Female thread (Hot & Cold) Outlet: One Brass G1/2" BSP Female thread
Guarantee	10 years against manufacturing faults (excluding serviceable parts)
Additional Information	1. Temperature: Pre-set 38°C, with push button override to 48°C 2. Automatic shut off in the event of hot or cold water supply failure

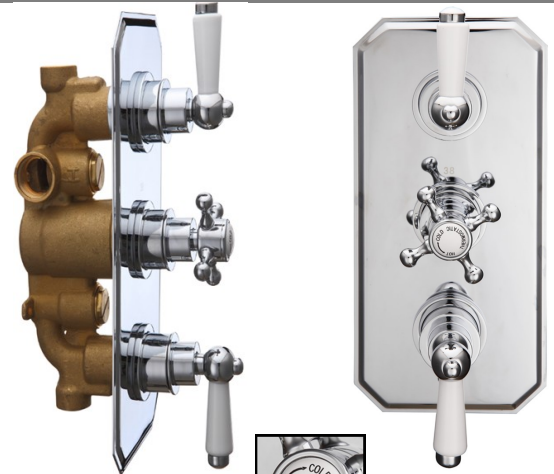

Operational Water Pressure



COMBI BOILER



HIGH PRESSURE
1.2 - 1.5+ bar

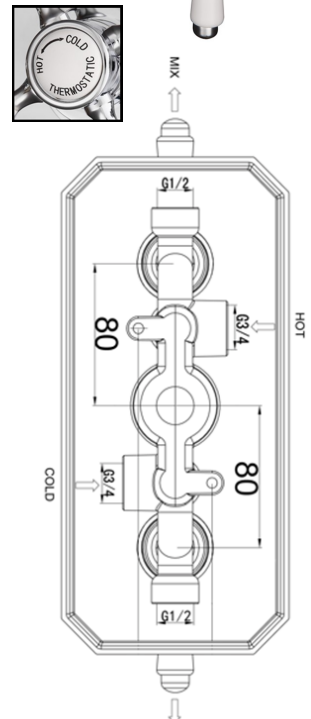
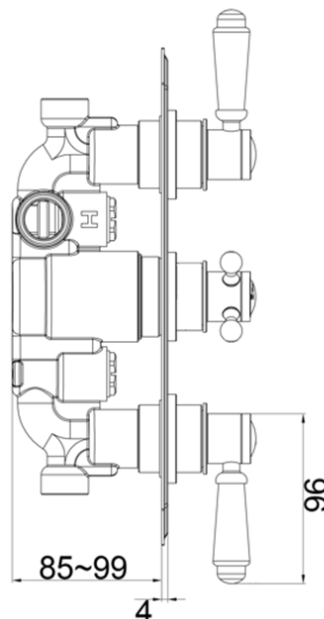
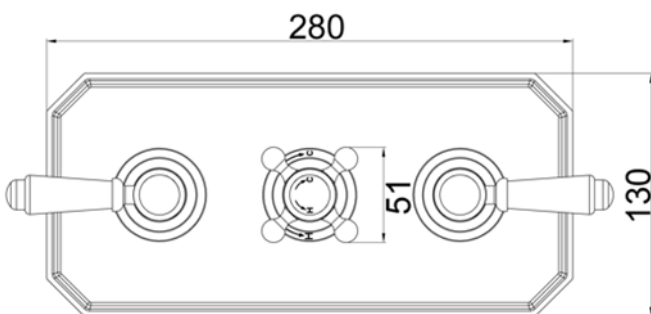

The information contained on this page was correct at the date of issue. Fitting dimensions are provided as a guide only. Some variation may occur due to manufacturing tolerances. We pursue a policy of continuing improvement in design and performance of our products and so reserve the right to change specifications without prior notice

FOR FURTHER ADVICE PLEASE CONTACT :-

SAGITTARIUS LTD UNIT 1 LOWER VICTORIA STREET—CHADDERTON—OLDHAM—OL9 9TU TEL:0616 6202029

EMAIL:TECHNICAL@SAGITTARIUSTAPS.CO.UK

Flow Rates (Litres per minute)

System Pressure	0.1 Bar	0.2 Bar	0.3 Bar	0.5 Bar	1.0 Bar	1.5 Bar	2.0 Bar	3.0 Bar	4.0 Bar	5.0 Bar
	-	-	-	13.5	19.5	22.8	27.7	34.2	39.5	44.2

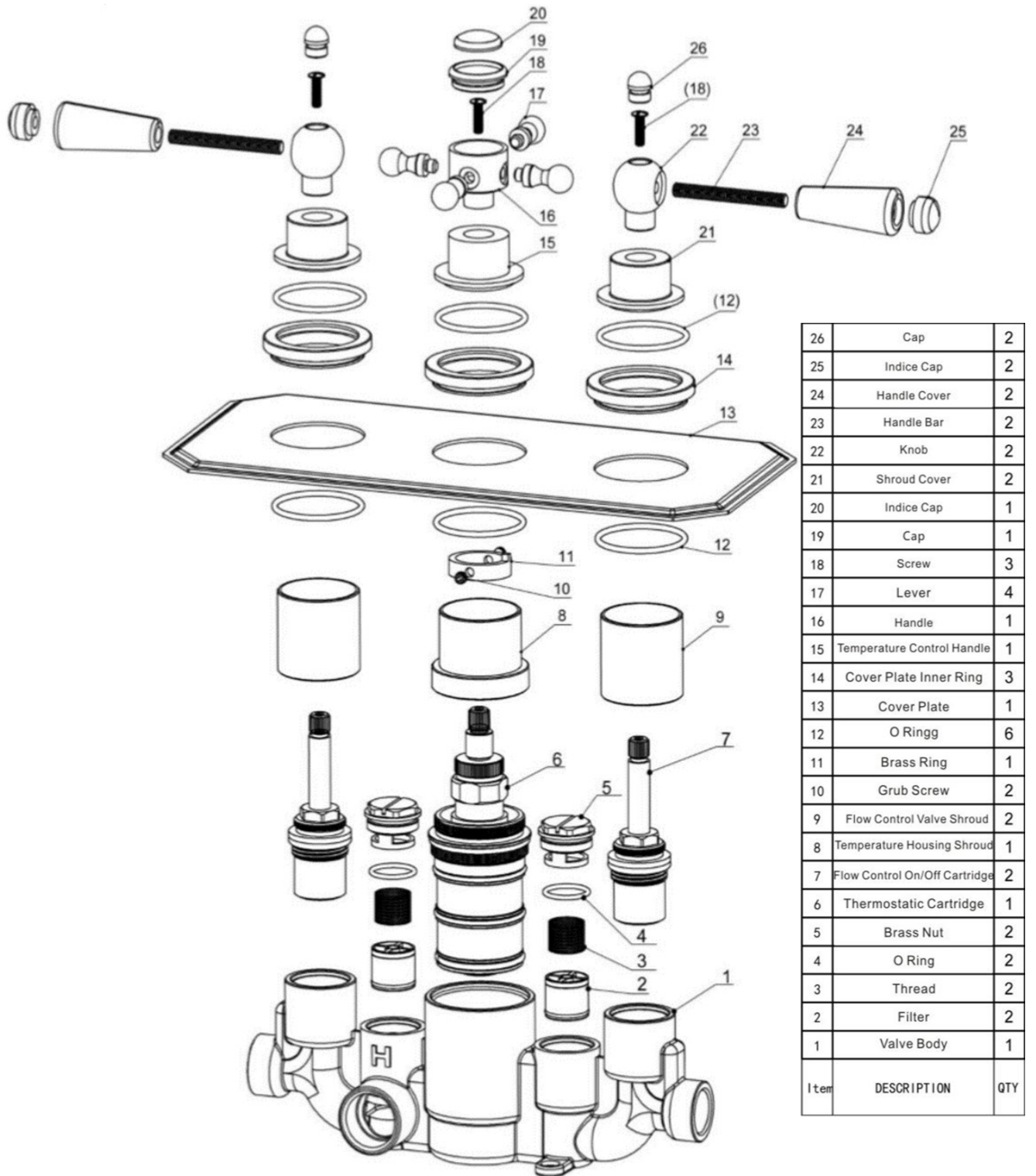

FOR FURTHER ADVICE PLEASE CONTACT :-

SAGITTARIUS LTD UNIT 1 LOWER VICTORIA STREET—CHADDERTON—OLDHAM—OL9 9TU TEL:0616 6202029

EMAIL:TECHNICAL@SAGITTARIUSTAPS.CO.UK