

# SAGITTARIUS

## TAPS & SHOWERING

### CONTRACT BASIN TAPS

CO/102/C

#### Construction

Brass Body  
(CuZn40Pb18); Zinc-  
alloy Handles  
Chrome plated to BS  
EN 248

#### Finishes

#### Product Type

Contemporary

#### Water Pressure Tested Between Standards

Min. 0.2 bar, Max. 6.0 bar

Complies with BS5412,  
BS EN200

#### Cartridge

1/4 Turn 1/2" Ceramic  
Disc Valves

#### Fitting

10mm G1/2" BSP Flex-  
ible inlet connection  
hoses

#### Aerator

Spout aerator

#### Guarantee

10 years against manu-  
facturing faults  
(excluding serviceable  
parts)



Water pressure

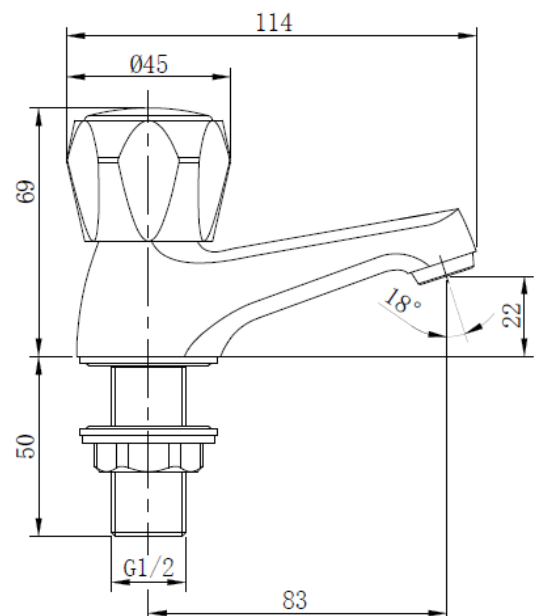
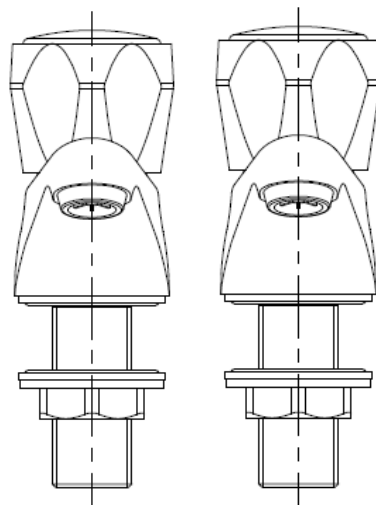

The information contained on this page was correct at the date of issue. Fitting dimensions are provided as a guide only. Some variation may occur due to manufacturing tolerances. We pursue a policy of continuing improvement in design and performance of our products and so reserve the right to change specifications without prior notice

FOR FURTHER ADVICE PLEASE CONTACT :-

SAGITTARIUS LTD UNIT 1 LOWER VICTORIA STREET—CHADDERTON—OLDHAM—OL9 9TU TEL:0616 6202029

EMAIL:TECHNICAL@SAGITTARIUSTAPS.CO.UK

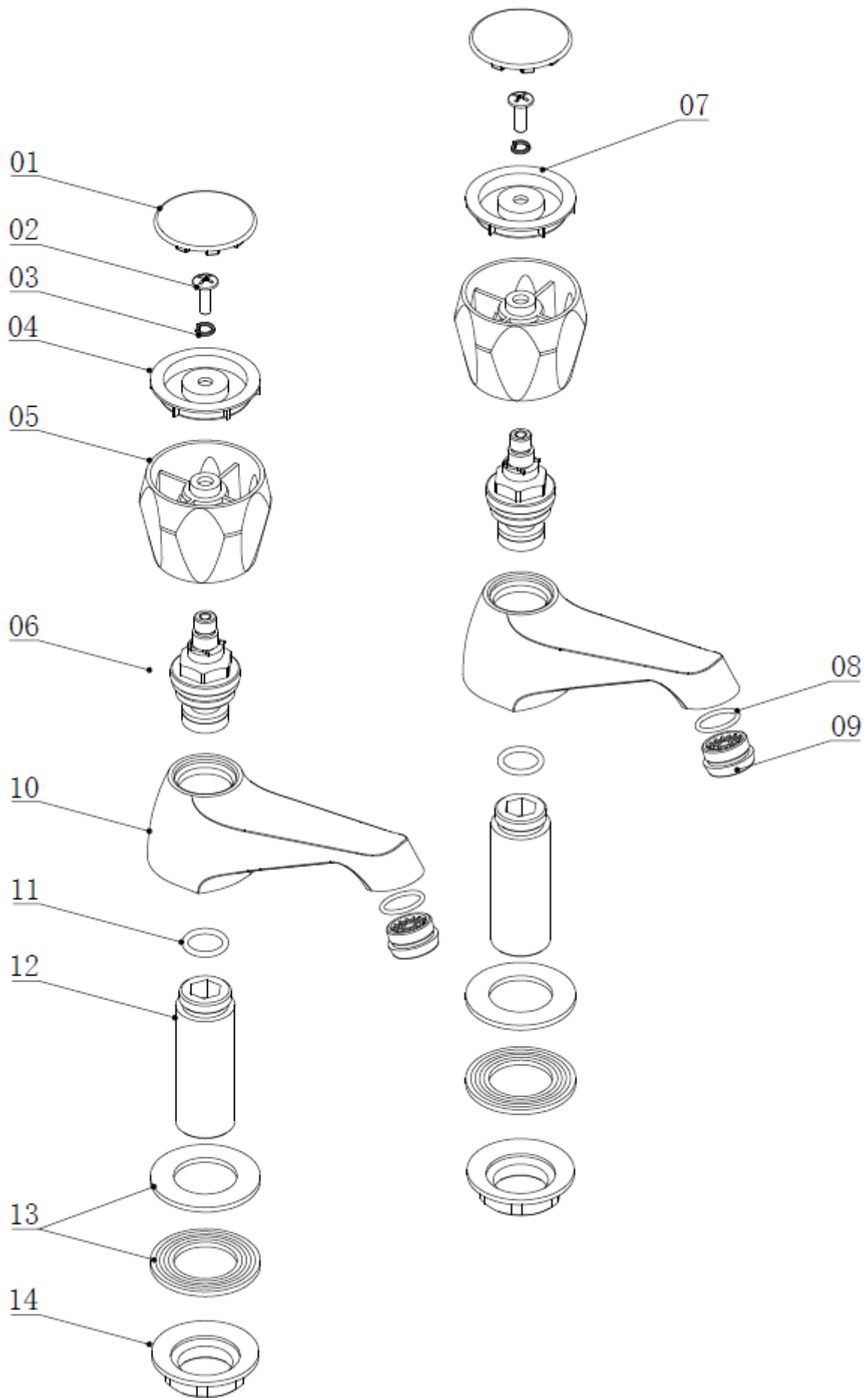

FOR FURTHER ADVICE PLEASE CONTACT :-

SAGITTARIUS LTD UNIT 1 LOWER VICTORIA STREET—CHADDERTON—OLDHAM—OL9 9TU TEL:0616 6202029

EMAIL:TECHNICAL@SAGITTARIUSTAPS.CO.UK