

SAGITTARIUS

TAPS & SHOWERING

CONTRACT BATH FILLER

CL/104C

Construction

Brass Body
(CuZn40Pb18); Zinc-
alloy Handles
Chrome plated to BS
EN 248

Finishes

Product Type

Contemporary

Water Pressure Tested Between Standards

Min. 0.2 bar, Max. 6.0 bar

Complies with BS5412,
BS EN200

Cartridge

1/4 Turn 1/2" Ceramic
Disc Valves

Fitting

10mm G1/2" BSP Flex-
ible inlet connection
hoses

Aerator

Spout aerator

Guarantee

10 years against manu-
facturing faults
(excluding serviceable
parts)



Water pressure



LOW PRESSURE
0.2-0.5 bar



COMBI BOILER
1.2-1.5+ bar



HIGH PRESSURE
1.2-1.5+ bar

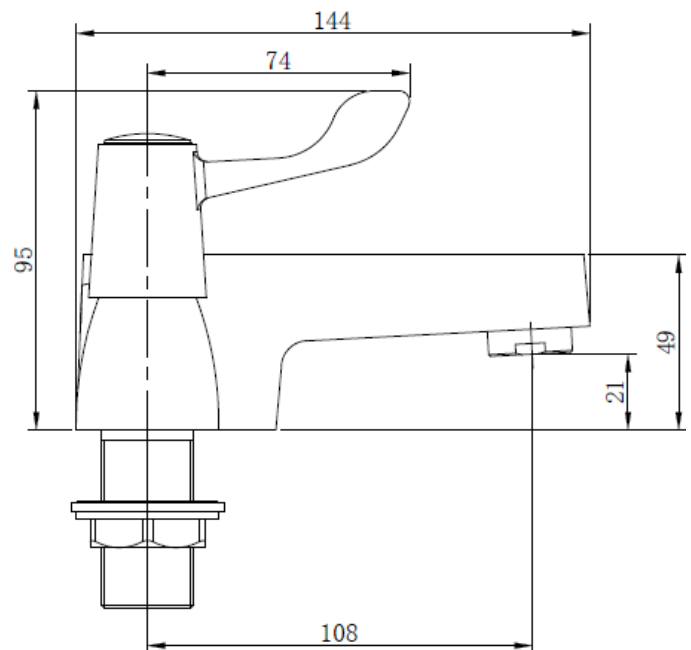
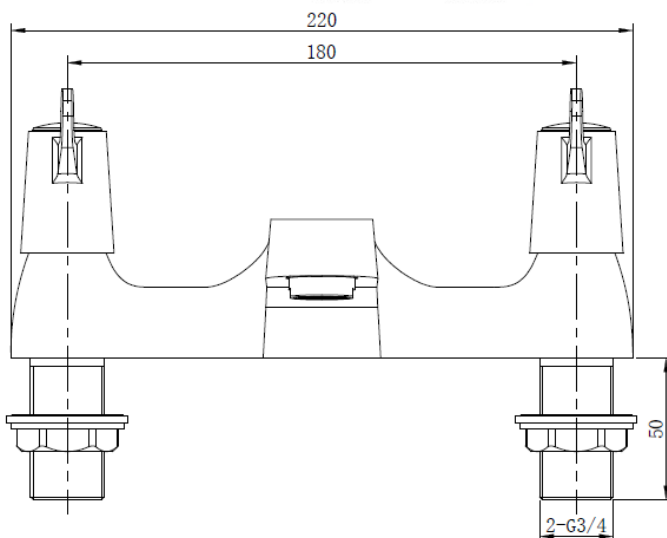

The information contained on this page was correct at the date of issue. Fitting dimensions are provided as a guide only. Some variation may occur due to manufacturing tolerances. We pursue a policy of continuing improvement in design and performance of our products and so reserve the right to change specifications without prior notice

FOR FURTHER ADVICE PLEASE CONTACT :-

SAGITTARIUS LTD UNIT 1 LOWER VICTORIA STREET—CHADDERTON—OLDHAM—OL9 9TU TEL:0616 6202029

EMAIL:TECHNICAL@SAGITTARIUSTAPS.CO.UK

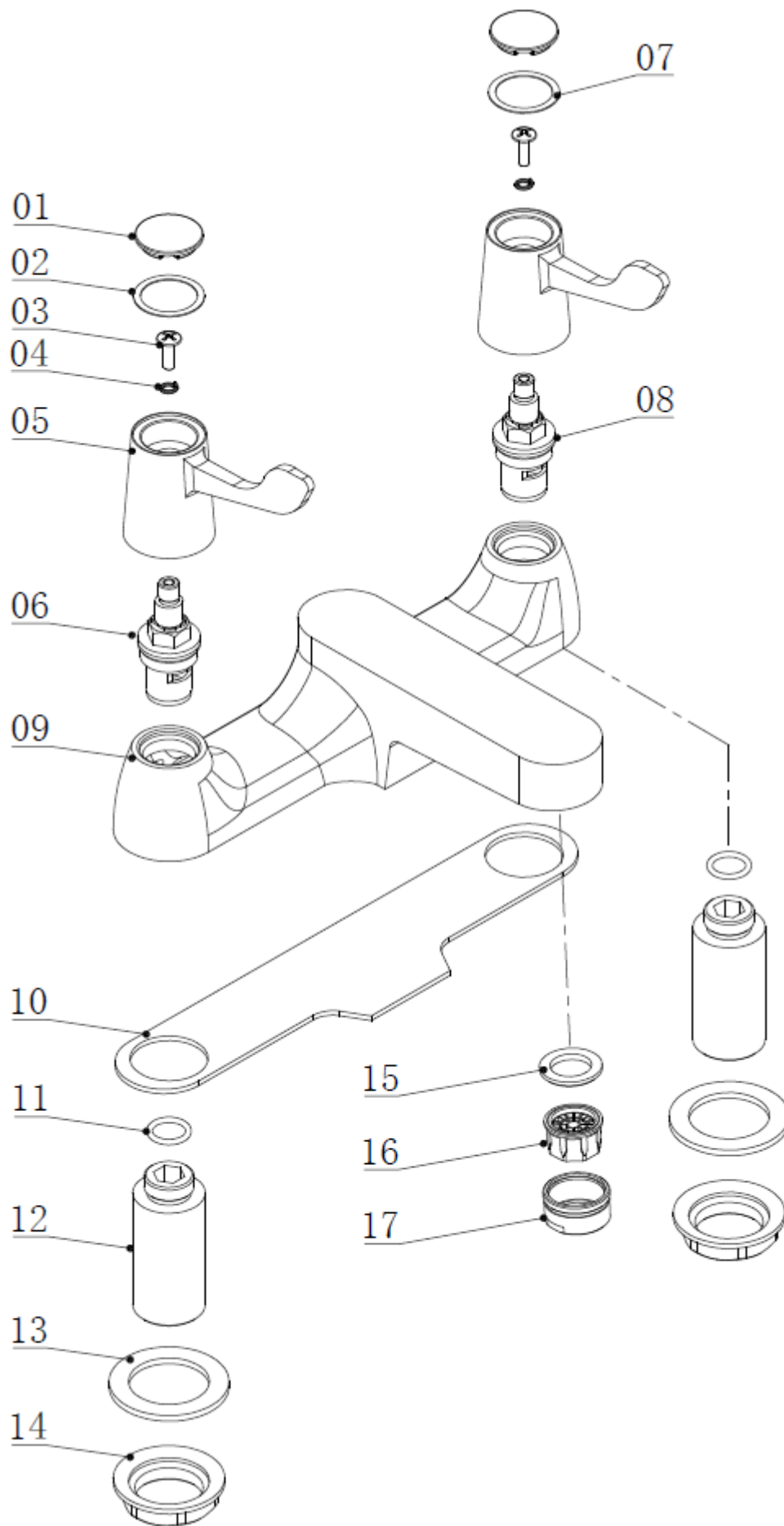

FOR FURTHER ADVICE PLEASE CONTACT :-

SAGITTARIUS LTD UNIT 1 LOWER VICTORIA STREET—CHADDERTON—OLDHAM—OL9 9TU TEL:0616 6202029

EMAIL:TECHNICAL@SAGITTARIUSTAPS.CO.UK