

SAGITTARIUS

TAPS & SHOWERING

CHURCHMAN HANDSET

CHROME

CH/659/C

- Construction** Brass & Ceramic Handle
Finishes Chrome
Product Type Traditional
Mode Single mode
Water Pressure Tested Between Min. 0.2 bar, Max. 6.0 bar
Fitting Brass G1/2" BSP Male thread
Packaging 49 x 42.5 x 37.5cm / carton (20 boxes),
 Dimension: 22 x 7 x 7cm / box;
 Weight: 0.360Kg / box
Guarantee 1 year against manufacturing faults
 (excluding serviceable parts)

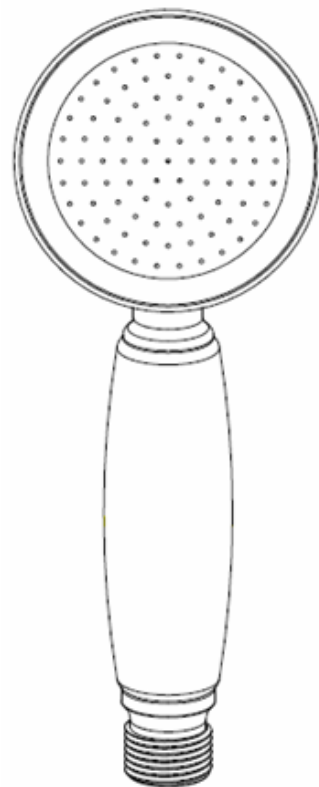
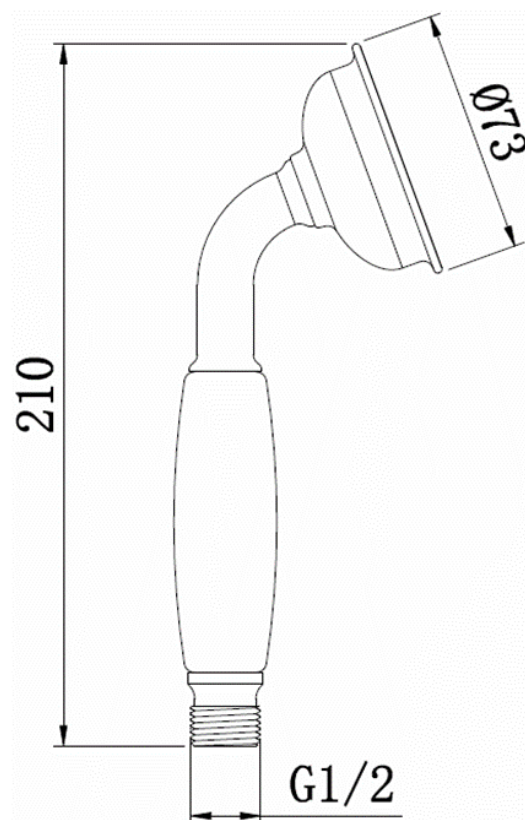

Flow Rates (Litres per minute)

System Pressure	0.1 Bar	0.2 Bar	0.3 Bar	0.5 Bar	1.0 Bar	1.5 Bar	2.0 Bar	3.0 Bar	4.0 Bar	5.0 Bar
	4.5	6.2	8.5	14.3	16.2	17.9	21.0	27.5	30.2	34.7

The information contained on this page was correct at the date of issue. Fitting dimensions are provided as a guide only. Some variation may occur due to manufacturing tolerances. We pursue a policy of continuing improvement in design and performance of our products and so reserve the right to change specifications without prior notice

FOR FURTHER ADVICE PLEASE CONTACT :-
 SAGITTARIUS LTD UNIT 1 LOWER VICTORIA STREET—CHADDERTON—OLDHAM—OL9 9TU TEL:0616 6202029
 EMAIL:TECHNICAL@SAGITTARIUSTAPS.CO.UK