

# SAGITTARIUS

## TAPS & SHOWERING

<b>Construction</b> alloy handle	Brass Body (CuZn40Pb18); Zinc
<b>Finishes</b>	Chrome plated to BS EN 248
<b>Product Type</b>	Contemporary
<b>Water Pressure</b>	Min. 0.5 bar, Max. 6.0 bar
<b>Tested Between</b>	
<b>Standards</b>	Complies with BS5412, BS EN200
<b>Cartridge</b>	1/4 Turn 1/2" Ceramic Disc Valves
<b>Fitting</b>	G1/2" BSP Flexible inlet hoses
<b>Guarantee</b>	10 years against manufacturing faults (excluding serviceable Parts)
<b>Additional Information</b>	Brass spray head, Nylon braided kink-resistant hose; 360° Swivel spout

### BOSTON PROFESSIONAL TWIN LEVER SINK MIXER CHROME BO/282/C



The information contained on this page was correct at the date of issue. Fitting dimensions are provided as a guide only. Some variation may occur due to manufacturing tolerances. We pursue a policy of continuing improvement in design and performance of our products and so reserve the right to change specifications without prior notice

FOR FURTHER ADVICE PLEASE CONTACT :-  
SAGITTARIUS LTD UNIT 1 LOWER VICTORIA STREET—CHADDERTON—OLDHAM—OL9 9TU TEL:0616 6202029  
EMAIL:TECHNICAL@SAGITTARIUSTAPS.CO.UK

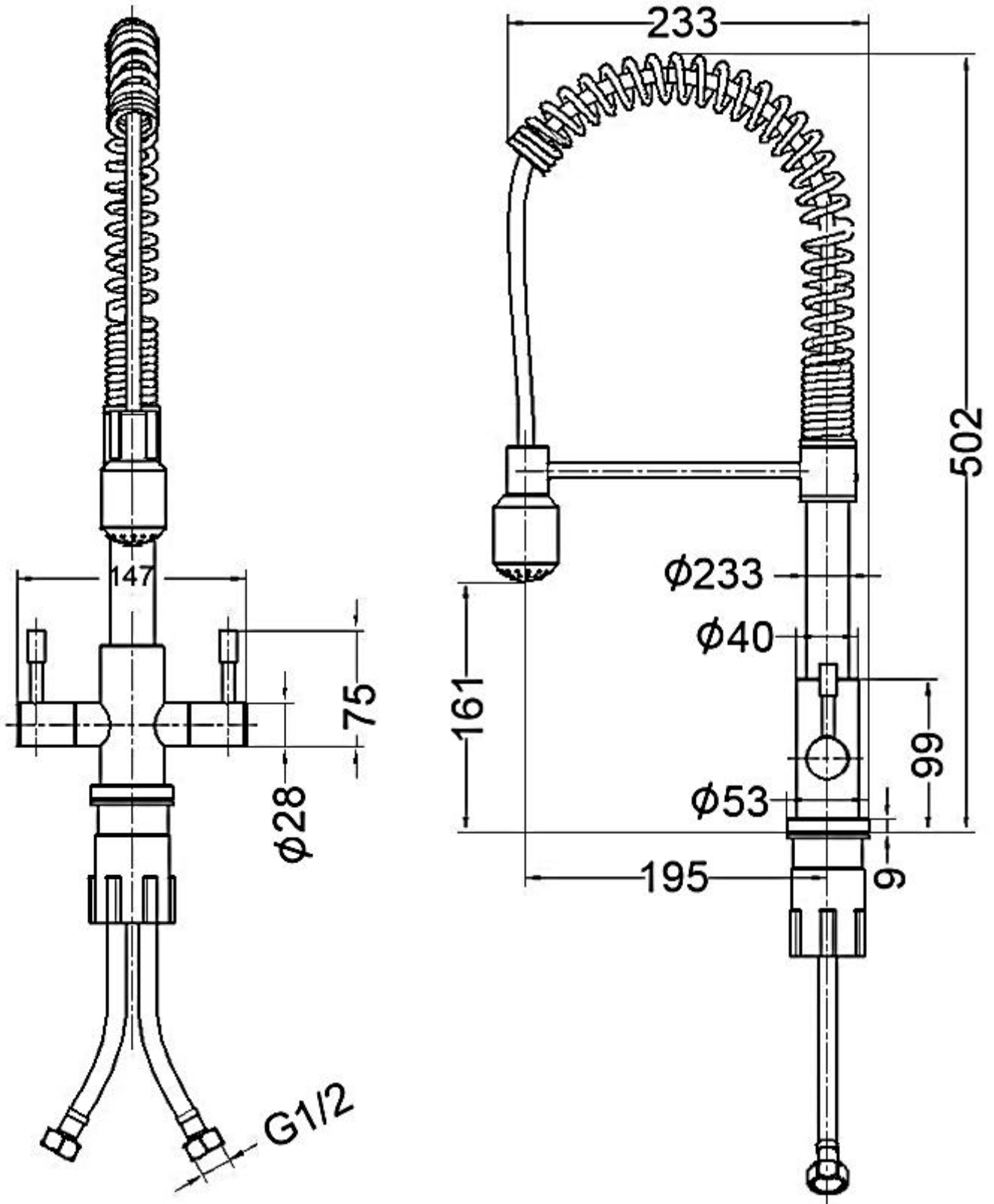

**Flow Rates (Litres per minute)**

System Pressure	0.1 Bar	0.2 Bar	0.3 Bar	0.5 Bar	1.0 Bar	1.5 Bar	2.0 Bar	3.0 Bar	4.0 Bar	5.0 Bar
	-	4.0	-	6.8	9.5	-	14.0	17.0	-	-

FOR FURTHER ADVICE PLEASE CONTACT :-

SAGITTARIUS LTD UNIT 1 LOWER VICTORIA STREET—CHADDERTON—OLDHAM—OL9 9TU TEL:0616 6202029

EMAIL:TECHNICAL@SAGITTARIUSTAPS.CO.UK

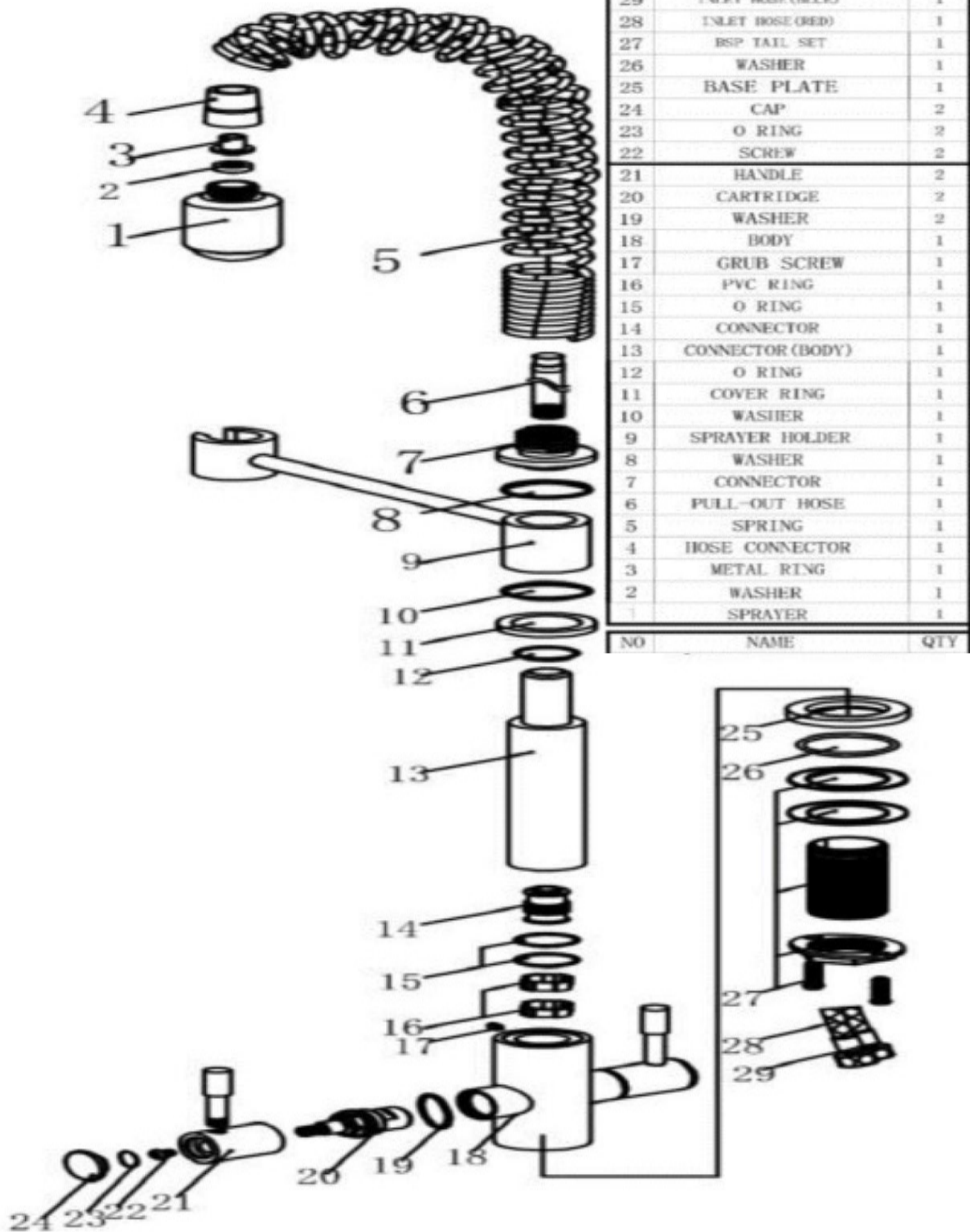

FOR FURTHER ADVICE PLEASE CONTACT :-

SAGITTARIUS LTD UNIT 1 LOWER VICTORIA STREET—CHADDERTON—OLDHAM—OL9 9TU TEL:0616 6202029

EMAIL:TECHNICAL@SAGITTARIUSTAPS.CO.UK